



RACING BRAKE PADS 2016

PRODUCT PORTFOLIO

The logo for PAGID RSL, featuring a stylized blue and grey icon to the left of the text "PAGID RSL" in a bold, sans-serif font, with "RSL" in yellow.

Long distance/endurance racing brake pads

The logo for PAGID RST, featuring a stylized blue and grey icon to the left of the text "PAGID RST" in a bold, sans-serif font, with "RST" in red.

Rally, sprint and stock car racing brake pads

The logo for PAGID RS, featuring a stylized blue and grey icon to the left of the text "PAGID RS" in a bold, sans-serif font, with "RS" in blue.

Premium organic based compound racing brake pads

The logo for PAGID RSC, featuring a stylized blue and grey icon to the left of the text "PAGID RSC" in a bold, sans-serif font, with "RSC" in grey.

Racing brake pads for ceramic composite discs

The logo for PAGID RSH, featuring a stylized blue and grey icon to the left of the text "PAGID RSH" in a bold, sans-serif font, with "RSH" in teal.

Racing brake pads for historic cars

The logo for PAGID RBF, featuring a stylized blue and grey icon to the left of the text "PAGID RBF" in a bold, sans-serif font, with "RBF" in blue.

Racing brake fluid

The logo for PAGID RBD, featuring a stylized blue and grey icon to the left of the text "PAGID RBD" in a bold, sans-serif font, with "RBD" in blue.

Racing brake disc



4

PAGID RSL - long distance/endurance racing brake pads

Excellent pad wear rate under endurance conditions, excellent disc life, less aggressive than RST giving best possible brake balance, modulation and consistency of friction under endurance conditions.

RSL compounds are developed to comply with latest requirements in endurance racing and in accordance with current ecological standards of the automotive industry.

RSL 1 :

Long distance/endurance compound with very good pad and disc wear, as well as friction stability vs temperature. Low pedal effort, slightly progressive in-stop behavior but still good modulation.

RSL 2 :

Newly developed endurance compound based on the RSL1. The friction level bridges the gap between RSL1 and RS29 but with improved pad and disc wear, as well as excellent friction stability vs. temperature. The base characteristics of low pedal effort, slightly progressive in-stop behavior with good modulation have been retained.



PAGID RST - rally, sprint and stock car racing brake pads

High average friction, aggressive in-stop behavior with instant pedal response and release, consistently firm pedal at all temperatures, fade resistant at highest disc temperatures.

RST 1:

High friction compound with very good initial bite and a progressive torque curve. Very fade resistant. Suitable for applications with high downforce and / or very high grip.

RST 2:

Medium to high friction and fade resistant compound with a mild progressive torque curve and good pedal feel. Recommended for GT and Touring Car racing on tracks where higher temperatures are an issue.

RST3:

Medium to high friction metal-ceramic type compound with good initial bite and still excellent modulation and release characteristics. Medium torque, fade resistant up to 800°C. Lowest heat conductivity in the RST range.

RST 4:

Medium friction, high heat tolerance with consistent repeatability. Also used for rear axle applications FWD cars and on long oval racing where more aggressive materials would disturb the vehicle set up. Recommended for formula and open wheel racing.



6

PAGID RS - premium organic based compound racing brake pads

Medium average friction, consistent in-stop behavior with good pedal feed back, favourable release characteristics reducing drag, good disc life, low heat conductivity.

RS 14:

Medium to high friction ceramic type compound with good initial bite, excellent release characteristic, very good modulation and controllability. Low wear rate and fade resistant up to 650°C. Newer compounds have replaced RS14 in some applications.

RS 19:

Low pad wear, very disc friendly, wide temperature range , yet most used pad in endurance racing. Due to excellent release characteristics and controllability also often used in shorter sprint races.

RS 29:

Combines the outstanding wear rate of the RS19 with a slightly higher initial bite and torque.

RS 42:

Medium friction compound with immediate low temperature response. Very easy bedding process. Classic Rally pad and also very popular in small formula cars. Newer compounds have replaced RS42 in some applications.

RS 44:

Medium friction compound with medium initial bite. Very good rear pad for RWD front engine and FWD cars. Newer compounds have replaced RS44 in some applications.



PAGID RSC - racing brake pads for ceramic composite discs

Race compounds specifically engineered for a variety of ceramic disc applications. The only available materials specifically developed for ceramic composite brake discs.

RSC 1:

Sprint race and track day compound for all known types of ceramic brake discs. This friction material features an ideal combination of cold friction, fade resistance and low thermal oxidation of the disc surface fibres.

RSC 2:

Special race compound for ceramic discs with a high fibre-content in the friction surface. Excellent fading stability, high friction level and low pad wear.

RSC 3:

Special race compound for ceramic discs with low fibre-content in the friction surface. Excellent fading stability, high friction level and low pad wear.



8

PAGID RBF - racing brake fluid

PAGIDRACING's High Performance Racing Brake Fluid has been specially formulated for racing applications, where braking systems consistently operate at very high temperatures. The typical dry boiling point of 330°C (626°F) is extremely high and guarantees maximum safety against vapor lock.

In addition to guarding against Vapor Lock, Pagid RS High Performance Racing Brake Fluid maintains its excellent viscosity, lubricity and compressibility performance at extreme temperatures, helping to maintain braking system reliability and performance.

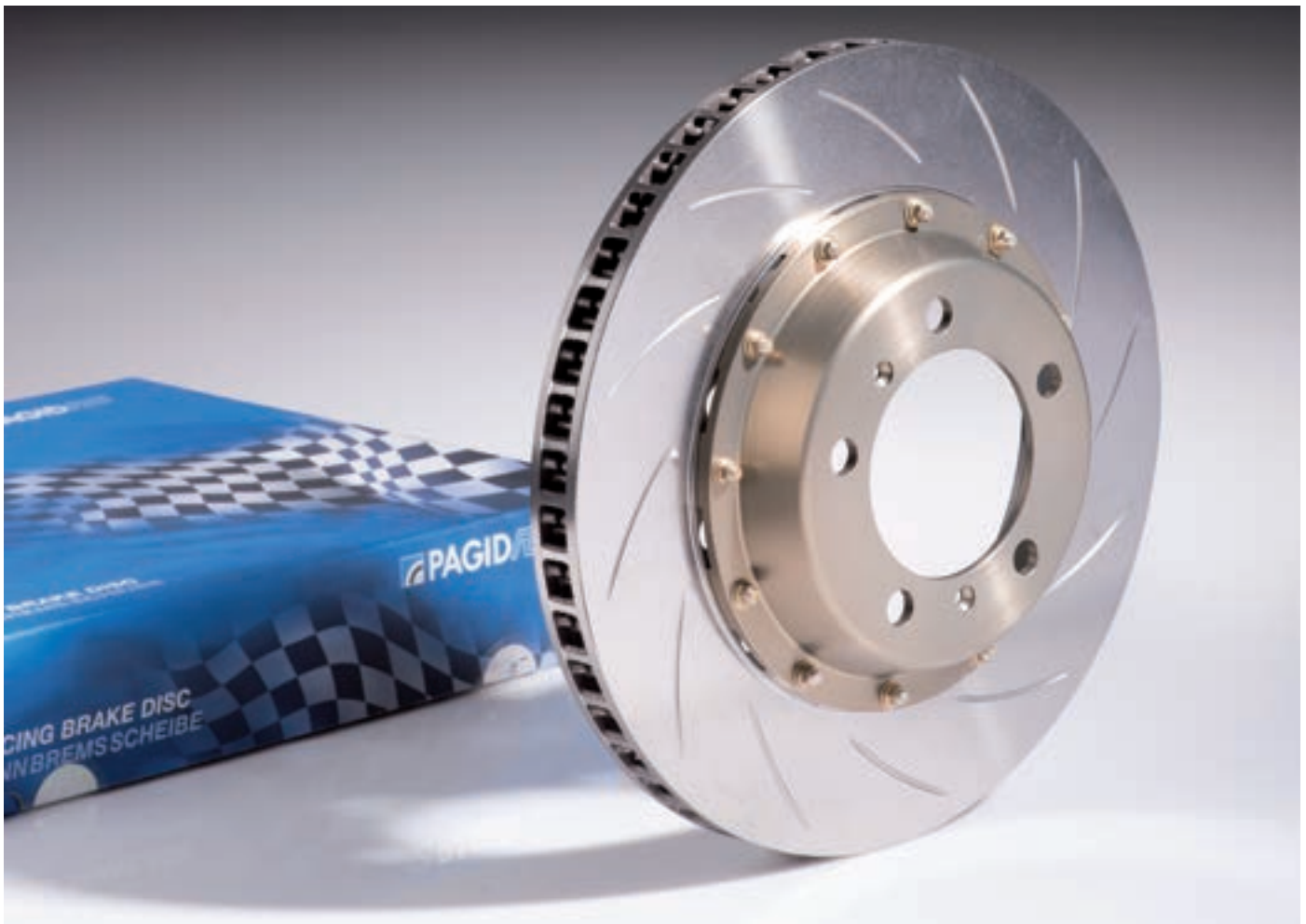

PAGID RBD - racing brake disc

High performance racing brake disc, two versions optimized for weight, cooling performance and crack resistance for either sprint or long endurance races.

The modular design allows the use of either the lightweight version (for sprint races or rally), or the endurance version with the same hat (bell) for specific vehicle applications.

DESIGN FEATURES

- The floating connection is between the bobbin and disc thus minimizing wear on the hat
- Hard anodized aluminium hats for increased surface hardness and wear resistance
- Hard anodized and minimal wear extends the usable life of the hat
- Careful attention has been paid to the airflow into the ventilation chamber and onto the outside friction face through then openings in the connection flange to the disc
- The ventilation chamber is specially designed to improve heat transfer from the disc to the cooling airflow
- The surface finish (groove pattern) has been developed in combination with Pagid*Racing* brake pads for optimal system performance and wear characteristics.

FRICITION VS TEMPERATURE

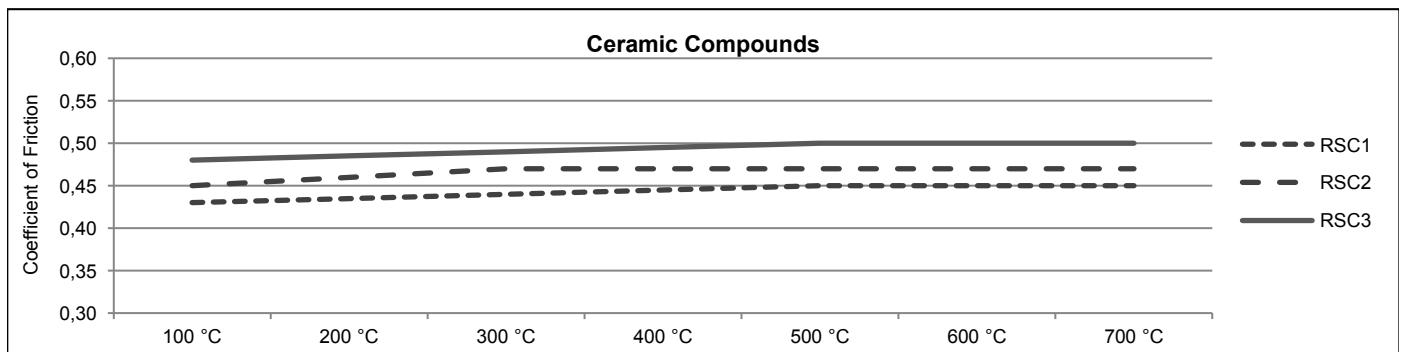
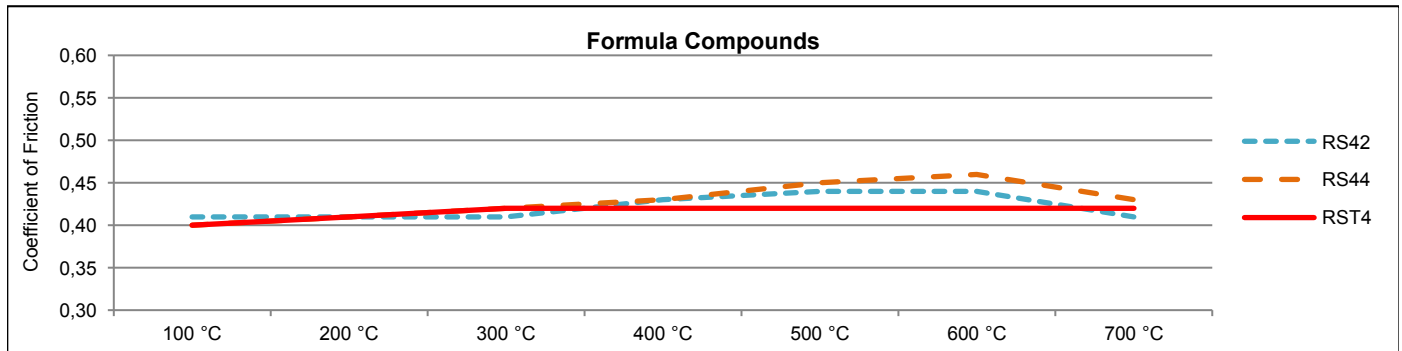
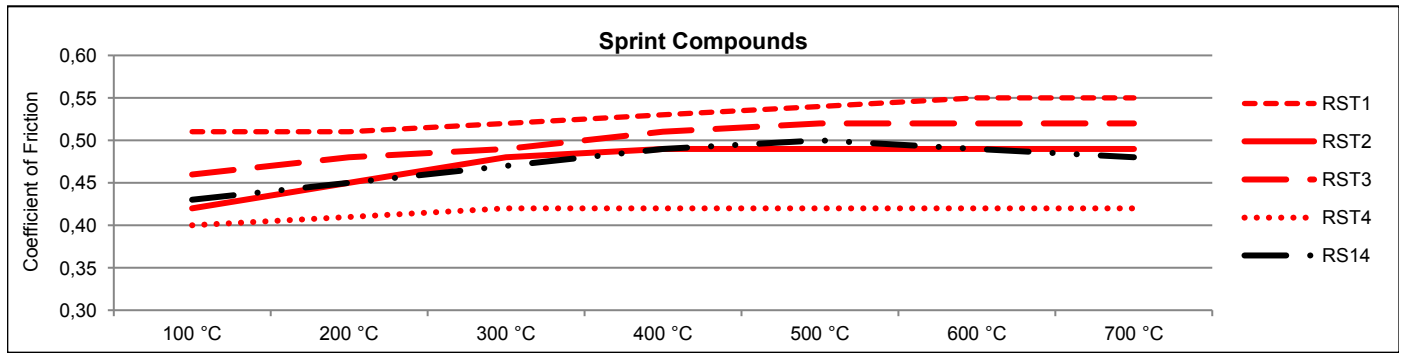
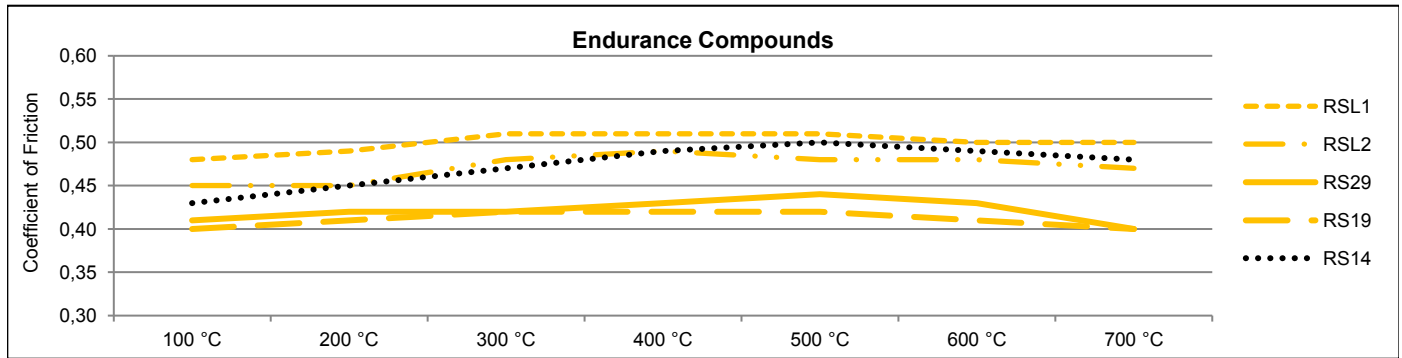

APPLICATION LIST RACE CARS

Make	Model	Year	Front	Rear
Acura see Honda				
Alfa Romeo	156 2.0 16V	95 - 98	1295	n.a.
	4C	13 -	8023	n.a.
Alpina	B3 [E90/E92]	07 - 10	4931	4933
	B5 F1 X	15 -	8200	4932
	B6 Biturbo [F12/F13]	12 -	4930	4932
	B6 GT3 [race car]	13 -	8092	8093
Aston Martin	DB 9	04 -	2487	1408
	DB 9 [ceramic brakes]		4941	4943
	Vanquish	03 - 08	1287	1408
	Vanquish [ceramic brakes]	12 -	4941	4943
	Vantage V12S [ceramic brake]	13 -	4941	4943
	Vantage V8 GT4 ProDrive [race car]	12 -	2487	1408
	Vantage V8 SP10	13 -	8081	1408
	Vantage V12 GT3 [race car]	13 -	8087	1674
Audi	80 2.2 Quattro S2	90 - 96	1276	n/a
	A1 2.0 TFSI Quattro	12 -	8001	4936
	A3 1.8 20V	96 - 03	2130	1158
	A3 1.8 20V Turbo	96 - 99	1678	1158
	A3 2.0 Quattro [8PA]	04 -	2130	8046
	A3 3.2 Quattro	06 -	8001	8046
	A3 RS3 Quattro	11 -	2487	8046
	A4 1.8 20V	95 - 00	1678	1158
	A4 & A6 [several]		8064	1158
	A4 & A5 & A6 & A7 [several]	08 -	8096	8039
	A8 D3 [ceramic brakes]	02 - 09	4907	8039
	RS3 (disc Ø 340mm) performance brake	15 -	8201	n/a
	RS4	00 - 02	2830	1158
	RS4	05 -	2931	8039
	RS5	10 -	2931	8039
	RS6 (C5)	02 - 04	2931	8039
	RS6 (C6)	08 - 10	8081	8039
	RS6 (C6) [ceramic brakes]	08 - 10	4910	8039
	R8	07 -	2931	1287
	R8 [ceramic brakes]	09 -	4907	1287
	R8 LMS GT3 [race car]	13 -	8087	1674
	R8 LMS GT3 [race car]	16 -	8100	2704
	Q5 (8R)	08 -	8096	8039
	S3	99 - 01	1678	1158
	S3 Quattro (disc Ø 345mm)	06 -	8064	8046
	S3 Quattro (disc Ø 340mm) performance brake	14 -	8201	n/a
	S4 [B6 + B7]	04 - 08	8064	8039
	S4 [B8] (disc Ø 345mm)	08 -	8096	8039

Please check with the appropriate drawing!

Make	Model	Year	Front	Rear
Audi	S5 (disc Ø 345mm)	07 -	8096	8039
	S6 [ceramic brakes]	12 -	4937	4938
	S7 [ceramic brakes]	12 -	4937	4938
	S8	99 - 02	1842	1158
	S8 [ceramic brakes]	02 - 10	4907	n/a
	S8 [ceramic brakes]	12 -	4937	4938
	TT	98 - 06	1678	1158
	TT R32	04 - 06	2830	1158
	TT 3.2 V6 Quattro (disc Ø 288mm)	06 -	8001	8046
	TT 3.2 V6 Quattro (disc Ø 345mm)	06 -	8064	8046
	TTS 2.0 Quattro	09 -	8064	8046
	TT RS 2.5 Quattro	09 -	2487	8046
	TT Cup [race car]	15 -	1539	1363
	Bentley	Continental GT [ceramic brakes]	03 - 11	4910
Continental GT [ceramic brakes]		11 -	4937	4938
Mulsanne [ceramic brakes]		10 -	4937	4938
Continental GT3 [race car]		14 -	2017	1674
BMW	120d & 130i [E81 & E87]	03 - 12	1295	8035
	135i [E82 & E88]	07 - 13	8084	8085
	1 Series M Coupe [E82]	11 - 13	8053	8021
	M135i [F20 & F21]	11 -	4931	4933
	M235i [F22]	13 -	4931	4933
	M235i Racing	14 -	8197	4933
	318is - 325i [E30]	82 - 93	1544	1141
	318is - 325i [E36]	90 - 98	2180	1285
	320i - 325i [E46]	98 - 05	2180	1285
	330i [E46]	00 - 05	1295	2685
	3 series M-Technic / Brembo	09 -	8084	8085
	320i - 330i [E90]	05 -	8053	8035
	335i , 335d [E90/E91/E92]	06 -	8053	8051
	850 [E31]	90 - 99	1427	2685
	M3 [E30] EVO I & II	86 - 92	1144	1285
	M3 [E36] 3.0 & 3.2	92 - 99	1295	1285
	M3 [E46] & M3 CSL	00 - 07	1295	2685
	M3 [E90 / E92]	07 - 13	8053	8021
	M3 [E92] GT4 race version	09 -	1538	1270
	M3 [F80]	14 -	4931	4933
	M4 [F32]	14 -	4931	4933
	M4 [F32] [ceramic brakes]	14 -	4934	1287
	M5 [E34]	88 - 97	1295	1285
	M5 [E39]	98 - 03	2683	2685
	M5 [E60]	04 - 11	8019	8021
	M5 [F10]	11 -	4934	4932
	M5 [F10] [ceramic brakes]	11 -	4935	4932
M6 [E63 / E64]	06 - 12	8019	8021	
M6 [F13]	12 -	4934	4932	

Make	Model	Year	Front	Rear
BMW	M6 [F13] [ceramic brakes]	12 -	4935	4932
	M6 GT3 [race car]	16 -	2019	1674
	X5 4.4	00 -	2683	2685
	Z1	88 - 91	1544	1285
	Z3 (not Roadster)	95 - 03	2180	1285
	Z3 M Roadster 3.2i	97 - 03	1295	1285
	Z4	03 -	2180	1285
	Z4 M Coupe	06 -	1295	2685
	Z4 GT3 [race car]	13 -	2558	1270
	Z8 4.9	00 - 03	2683	2685
	Mini Cooper	02 - 06	2959	n.a.
Cadillac	CTS-V (4 piston front caliper)	03 - 09	2487	1408
	CTS-V (6 piston front caliper)	10 -	8081	1408
Caterham	Seven Range	97 -	3102	1163
	stock AP up-grade	97 -	1265	1363
	SP/300.R	12 -	4349	4349
Chevrolet	Corvette C5 base, Z06	97 - 04	2213USA	8109
	Corvette C5 & C6 base	05 -	2213USA	8109
	GM Intermediate D52, several models		1594USA	
	GM Metric D154, several models		1595USA	
	Cobalt SS Turbocharged	08 -	8023	n.a.
	Corvette Brembo non ceramic	09 -	8091	2487
	Corvette Brembo [ceramic brakes]	09 -	8091	4906
	Corvette C7 base	14 -	2487	8208
	Corvette C7 Z51	14 -	2487	8208
	Corvette C7 Z06 [ceramic brakes]	15 -	8091	4906
	Corvette C7 GT3 [Callaway Race Car]	15 -	2017	1674
	Callaway Z06.R GT3 [race car]	13 -	8087	1270
	Camaro SS	09 -	2487	1408
	Camaro ZL1	12 -	8081	1408
Camaro Z28 [ceramic brakes]	15 -	8091	4906	
Citroen	ZX 2.0 16V	96 -	1544	1610
	Saxo 1.6 VTS (Cup)	96 -	2388	1610
	DS3 R1	15 -	8212	n.a.
	DS3 R3 Tarmac Rally	15 -	1595	3102
Dodge	Viper	92 - 00	1408	1682
	Viper	01 - 02	1408	n.a.
	Viper SRT-10	04 -	1287	1287
	Viper Competition Coupe	03 -	1287	1287
	Viper SRT TA	14 -	2487	2487
	Viper SRT TA (time attack)	14 -	2487	2487
Ferrari	348 GTB, GTS, Spider	89 - 94	1203	1203

Please check with the appropriate drawing!

Make	Model	Year	Front	Rear
Ferrari	355 Berlinetta, GTS	94 - 99	1203	1203
	355 Challenge	95 - 00	1674	1674
	360 all models	99 - 05	1408	1408
	360 Challenge	99 - 05	1896	1595
	360 Challenge Stradale [ceramic brakes]	03 - 05	8083	4906
	Enzo [ceramic brakes]	02 - 04	8083	4906
	F430 [cast iron brakes]	05 - 10	1408	1408
	F430 [ceramic brakes]	05 - 10	8083	4906
	430 Scuderia [ceramic brakes]	07 - 10	8091	4906
	430 Challenge [ceramic brakes]		8091	4906
	Several ceramic brakes CCM		8091	4906
	456 GT	94 - 96	1427	1203
	458 Italia [ceramic brakes]	10 -	8091	4906
	458 Speciale [ceramic brakes]	13 -	4580	4581
	458 Italia GT3 [race car]	13 -	8100	1674
	488 GT3 [race car]	16 -	8101	1674
	512 Testarossa	92 - 96	1287	1203
	F512M & 550		1427	1203
	575M Maranello	02 - 06	1427	1203
	599 GTB Fiorano	06 - 12	8091	4906
F40 Street and race	87 - 92	1287	1287	
F50	95 - 97	1287	1287	
Fiat	Punto Abarth 1.4	07 -	n.a.	4940
Ford	Fiesta & Puma 16V	96 - 02	4823	n.a.
	Fiesta R5 Tarmac Rally	15 -	1616	1616
	Fiesta R5 Gravel Rally	15 -	1617	1617
	GT	04 - 06	2487	2487
	Mustang Shelby GT500 [4 piston Brembo caliper]	07 - 14	2487	8113
	Mustang Shelby GT500 [6 piston Brembo caliper]	13 - 14	8005	8113
	Mustang Boss 302	12 -	2487	8113
	Mustang Boss 302S	13 -	1674	8113
	Mustang GT [with performance package]	15 -	8203	8204
	Mustang Shelby GT350	15 -	8203	8204
Focus II 2.5RS	09 -	8096	n.a.	
Ginetta	LMP3 [race car]	15 -	2488	2488
	G55 GT3 [race car] with PFC brakes		4923	8093
	G55 GT4 [race car]		1539	1595
Honda (Acura)	Accord Type R	97 - 03	2623	1158
	Integra Type R DC2	96 - 01	2623	n.a.
	NSX	90 - 05	2623	n.a.
	Civic Type R; S2000; RSX	99 - 05	8010	8066
	Acura TL	04 -	2487	n.a.
	Civic Type R	06 -	n.a.	8066
	Civic TCR [race car]	15 -	1904	1363

Make	Model	Year	Front	Rear
Hyundai	Genesis Coupe 3.8 track	10 -	2487	1408
Jaguar	F Type	14 -	8019	n.a.
KTM	X-Bow	08 -	1408	1587
	X-Bow GT4	15 -	8222	1674
Lamborghini	Aventador LP700-4 [ceramic brakes]	11 -	4937	4906
	Diablo Brembo brakes	92 - 99	1287	1287
	Gallardo	04 - 13	2931	1287
	Gallardo [ceramic brakes]	04 - 13	4907	1287
	Gallardo LP 600 GT3 [race car]	13-	8087	1674
	Gallardo GT3 [race car]	14-	2488	1674
	Huracan [ceramic brakes]	14 -	4907	1287
	Huracan GT3 [race car]	15 -	8101	1674
	Huracan Trophéo [race car]	15 -	8101	1674
	Murciélago [non ceramic]	01 - 10	1287	1287
	several ceramic brakes		4907	4906
	Lancia	Delta 2.0 HF Int.16V Evo	91 - 94	1408
Lexus	IS-F	08 - 11	8005	n.a.
Lotus	Esprit Turbo	94 - 96	1408	1408
	Elise	96 -	2593	1682
	Evora	09 -	4345	8214
	Exige	03 -	2593	1682
	Exige Sport Cup	06 -	4349	1682
Maserati	BiTurbo 2.5 & 2.8	94 - 99	2683	2685
	Spyder 4.2 & Coupe 3.2	02 - 07	1427	1203
	Grand Turismo	07 -	8005	1408
	Trofeo MC		2488	1283
Mazda	MX-5 Miata	06 -	8082	8077
	MX-5 Miata Global Cup Car	16 -	8023	8077
	Speed 3 & 6	07 -	8064	n.a.
McLaren	F1	92 - 98	1287	on request
	MP4-12C	11 - 14	4346	4345
	MP4-12C [ceramic brakes]	11 - 14	8091	8187
	MP4-12C GT3 [race car] Akebono caliper	13 -	2557	1674
	650 S	14 -	4346	4345
	650 S [ceramic brakes]	14 -	8091	8187
Mercedes	A 45 AMG (W176)	13 -	8188	8189
	CLA 45 AMG	13 -	8188	8189
	CLA Cup (race car)	12 -	1539	8189

Please check with the appropriate drawing!

Make	Model	Year	Front	Rear
Mercedes	C class w. AMG sport pack	07 -	8094	n.a.
	C63 AMG	08 -	8081	8031
	CLK 63 AMG Black Series	08 -	8081	8031
	CLS 63 AMG [ceramic brakes]	11 -	8088	8089
	E55 AMG (W211)	02 -	8027	8031
	E class w. AMG sport pack	09 -	8094	n.a.
	SLK Roadster 32 AMG (R170)	01 - 04	2830	n.a.
	SLK 55 AMG (R171)	04 - 11	8005	8031
	SLK 55 AMG (R172)	12 -	8188	8189
	SLR	04 -	8027	8031
	SLS AMG [ceramic brakes]	09 -	8088	8089
	SLS AMG GT3 [race car]	13 -	8101	1674
	AMG GT3 [race car]	16 -	2561	1674
Mitsubishi	3000 GT	92 - 96	1591	n.a.
	3000 GT VR4	92 - 99	1406	n.a.
	Lancer Evo III	92 - 94	1591	1897
	Lancer Evo IV	95 - 97	1591	2445
	Lancer Evo V - Evo IX	98 - 06	2487	1587
	Lancer Evo X	07 -	2487	8069
	EVO X R4 / Super Gr. N Tarmac Spec.	15 -	2931	8234
Nissan	300ZX	89 - 97	1406	n.a.
	Skyline GTR	89 - 95	1427	1587
	350 Z Coupe Track	02 -	1427	1587
	R35 GTR	08 -	8081	1287
	R35 GTR [ceramic brakes]	08 -	4945	4946
	GT-R NISMO GT3 [race car]	15 -	2560	1272
Opel	Adam Rallye Cup	12 -	8023	4940
	Adam Rallye R2	14-	2555	4940
	Astra F 2.0 GSI 16V	91 - 98	1288	1177
	Astra G OPC	99 - 03	2275	8185
	Astra H OPC	05 - 09	2275	8185
	Astra J OPC	09 -	2275	4939
	Astra OPC [race car]	15 -	1539	1363
	Calibra 2.0i 16V	90 - 94	1288	1177
	Corsa B 1.6 GSI 16V	93 - 00	1620	n.a.
	Corsa D 1.6 Turbo	07 -	n.a.	4940
	Kadett E 2.0 GSI 16V	88 - 91	1288	1177
	Speedster 2.2i 16V	00 - 05	2593	1682
Peugeot	205 1.9 GTI	87 - 98	3276	1610
	306 2.0 S16	93 - 98	2388	1610
	309 1.9 GTI 16V	90 - 93	3276	1610
	405 2.0 MI 16	92 - 95	2388	1158
	406 Coupe Brembo brake	97 - 04	1408	n.a.

Make	Model	Year	Front	Rear
Pontiac	GM Intermediate D52, several models		1594USA	
	GM Metric D154, several models		1595USA	
Porsche	911 2.7 / 3.0 / 3.2 Carrera	72 - 89	4501	4304
	911 3.3 SC Turbo / Turbo S	77 - 90	1203	1203
	928 S & S4 & GT	85 - 95	1204	1203
	928 5.4 GTS 32V	91 - 95	1842	1203
	944 2.5 Turbo	85 - 87	1203	1203
	944 2.5 Turbo	87 - 91	1204	1203
	944 2.7 & 3.0 S2	88 - 91	1203	1203
	959 2.8	87 - 91	1842	1842
	964 C2 3.6	88 - 91	1203	1580
	964 C2 3.6	91 - 94	1203	1203
	964 3.6 Carrera RS	91 - 93	1204	1203
	964 3.6 C4	88 - 94	1203	1203
	964 3.3 Turbo & Turbo S	88 - 91	1204	1203
	964 3.3/3.6 Turbo & Turbo S	91 - 93	1842	1203
	968 3.0 Coupe	91 - 95	1203	1203
	968 3.0 Coupe Sport	91 - 95	1204	1203
	968 3.0 Coupe Turbo S	93 - 95	1842	1203
	993 3.6 Carrera & C4	93 - 97	1204	1203
	993 4S (turbo look)	96 - 97	1842	1204
	993 3.6 Turbo & Turbo GT2	95 - 97	1842	1204
	993 3.8 Carrera RS & RSR	95 - 97	1842	1204
	993 GT2 & RSR (380 disc)	95 - 97	1908	1204
	996 3.4C & 3.6	97 - 05	2405	2406
	996 3.6C 4S	03 - 05	2474	2405
	996 3.4C Cup	97 - 98	1842	2405
	996 3.4C Cup	99 - 01	2474	2405
	996 GT3	99 - 01	2474	2405
	996 GT2	02 - 05	2707	2405
	996 GT3	02 - 05	2707	2405
	996 Turbo	99 - 05	2474	2405
	996 GT3 Cup	02 - 05	2707	2405
	996 GT3 RS [street car]	03 - 05	2707	2405
	996 GT3 R & GT3 RS [race car]	00 - 05	1908	1674
	997 3.6 C & 3.6 C4	05 - 09	2405	2406
	997 3.8 C S & 3.8 C 4S	05 - 08	2474	2405
	997 3.6C & 3.6C4	08 -	8074	8006
997 3.8 C S & 3.8 C 4S	09 -	2474	8006	
997 3.8 Carrera GTS	09 -	2474	2405	
997 Turbo	06 -	2707	8006	
997 GT3	07 -	2707	8006	
997 GT3RS	07 -	2707	8006	
997 GT3 Cup	05 -	8004	8006	
997 GT3 Cup Grand Am spec.	07 -	8038	8037	
997 GT3 Cup S	08 -	8038	8037	
997 GT3 RSR	07 -	2488	1674	

Please check with the appropriate drawing!

Make	Model	Year	Front	Rear
Porsche	997 all models ceramic brakes	05 -	2707	8006
	991 3.4 Carrera [iron brakes]	11 -	8074	4918
	991 3.8 Carrera S [iron brakes]	11 -	4922	4909
	991 3.4 Carrera [ceramic brakes]	11 -	4908	4909
	991 3.8 Carrera S [ceramic brakes]	11 -	4908	4909
	991 Turbo [iron brakes]	13 -	4924	4925
	991 Turbo [ceramic brakes]	13 -	4927	4925
	991 GT3 [iron brakes]	13 -	4924	4925
	991 GT3 [ceramic brakes]	13 -	4927	4925
	991 GT3 RS [iron brakes]	15 -	4924	4925
	991 GT3 RS [ceramic brakes]	15 -	4927	4925
	991 GT3 Cup [PFC brakes 22/20mm]	13 -	4920	4921
	991 GT3 Cup [PFC brakes 28/26mm]	13 -	4928	4929
	Boxster [986]	96 - 05	2407	2406
	Boxster S [986]	99 - 05	2405	2406
	Boxster [987]	05 -	2407	2406
	Boxster S [987]	05 - 12	2405	2406
	Boxster [987] [ceramic brakes]	05 - 12	2707	2405
	Boxster 2.7 [981]	12 -	8074	2406
	Boxster S 3.4 [981]	12 -	8074	2406
	Boxster GTS 3.4 [981]	14 -	8074	2406
	Boxster Spyder	15 -	4922	4909
	Carrera GT	04 - 06	2707	2707
	918 Spyder	13 -	4927	4925
	Cayenne Turbo (18" wheels)	02 - 10	2845	2406
	Cayenne [cast iron & ceramic brakes]	06 -	4917	4918
	Cayman [987]	06 - 09	2407	2406
	Cayman [987]	09 - 12	2405	2406
	Cayman [987] [ceramic brakes]	06 - 12	2707	2405
	Cayman S [987]	06 - 12	2405	2406
	Cayman R [987] (none ceramic)	10 -	2405	2406
	Cayman 2.7 [981]	13 -	8074	2406
	Cayman S 3.4 [981]	13 -	8074	2406
	Cayman GTS 3.4 [981]	14 -	8074	2406
	Cayman S [981] [ceramic brakes]	13 -	4908	4909
	Cayman GT4	16 -	4924	4925
	Cayman GT4 [ceramic brakes]	16 -	4927	4925
	Cayman GT4 Clubsport	16 -	4928	4929
	Panamera [cast iron & ceramic brakes]	09 -	4917	4909
	Renault	Clio 1.8 16V & 2.0 16V	91 - 98	3276
Clio II 3.0 V6 mid engine		00 - 05	1408	1408
Clio 3.0 V6 Turbo Sport		98 -	4345	n.a.
Clio III 2.0 16V Sport		05 -	8023	1158
Megane Coach 2.0 16V		96 -	1702	1610
Megane RS & Clio Cup		05 -	8023	1158
Seat	Ibiza & Toledo 16V	91 - 99	1743	1158

Make	Model	Year	Front	Rear
Seat	Toledo 2.3i V5	99 -	1678	1158
	Leon 2.8 Cupra 4 (Brembo)	01 - 06	1408	1158
	Leon 1.8T Cupra R (Brembo)	03 - 06	1408	1158
	Leon Cupra Cup MK2 [race car]	07 - 13	4346	1158
	Leon Cup Racer MK3 [race car]	14 -	1539	1363
	several		8064	
Skoda	Octavia 1.8i 20V Turbo	97 -	1678	1158
	several		8064	
Subaru	WRX Japan + EU	98 - 03	1406	n.a.
	Impreza 2.5 WRX (system Tokico)	11 -	8174	n.a.
	STI	03 -	2487	1587
Toyota	Yaris Cup & MR2 Spyder		8029	n.a.
	Yaris 1.3	06 -	4913	n.a.
	GT86 2.0GT R3 Rally	15 -	1595	3102
	GT86 2.0GT (system Tokico)	12 -	8174	8175
Volvo	S60 Turbo R Brembo brakes	03 -	2487	1408
	V70 R 2.5T Brembo brakes	03 -	2487	1408
VW	Golf III 2.0i GTI 16V & VR6	92 - 96	1743	1158
	Golf III 2.0i GTI 16V & VR6	96 - 97	1678	1158
	Golf IV (1J) 1.8 & 2.0	97 - 04	2130	1158
	Golf IV 1.8 Turbo & 2.3i V5	97 - 04	1678	1158
	Golf IV 2.8i V6	99 - 04	1678	1158
	Golf IV 3.2 R32	02 - 05	2830	1158
	Golf V GTI (disc Ø 288mm)	04 - 08	8001	8046
	Golf V GTI (disc Ø 345mm)	04 - 08	8064	8046
	Golf V 3.2 R32	05 - 08	8064	8046
	Golf VI GTI (disc Ø 312mm)	09 - 12	8001	4936
	Golf VI 2.0R 4motion (disc Ø 345mm)	09 - 12	8064	8046
	Golf VII 2.0 GTI (disc Ø 340mm) performance brake	13 -	8201	n.a.
	Golf VII 2.0 R 4motion (disc Ø 340mm) performance brake	13 -	8201	n.a.
	Golf TCR [race car]	15 -	1539	1363
	Lupo 1.6 GTI	00 - 05	1743	1158
	New Beetle 1.6 & 1.9 Tdi	99 - 10	2130	1158
	New Beetle 1.8 Turbo 20V	99 - 10	1678	1158
	New Beetle 2.3 & 3.2 V6	00 -	1678	1158
	Polo (6N) 1.3i & 1.4i	94 - 99	4011	n.a.
	Polo (6N) 1.4i 100 16V	99 - 01	1743	1158
	Polo (6N) 1.6 GTI	98 - 01	1743	1158
	Touareg V10 TDI & 4.2 V8	02 -	2845	8069
	Touareg [ceramic brakes]	08 -	4917	4918

APPLICATION LIST CALIPER

Make	Race Caliper	Pad Thickness	Part. Nr.	
Alcon	B type [4441]	16mm / 20mm / 22mm / 25mm	1595 / 1607 / 8037 / 1674	
	CAR94, CAR12 [4494]	30mm	2016	
	CAR9549Y76 D52	29mm	2488	
	CAR9549Y76 D64	29mm	8100	
	DP88, TA6+, CAR95 [4495]	26.5mm / 29mm	2688 / 2557	
	F type [4448]	20mm / 25mm	1218 / 1220	
	H type [4463] D40 / D44 / D48	16mm	1749 / 2127 / 1265	
	K type [4476]	15mm / 20mm	2743 / 1756	
	Mono4 [PNP4498]		8050	
	Mono6 [4497 x 500]		8028	
	P type [4436]	15.5mm / 17.5mm	8009 / 1203	
	R type [3451] D42 / D48 see also historic catalogue	14.4mm	3102 / 3190	
	SR, CAR22 [4422] D43	20mm / 16mm	1283 / 1705	
	SR, CAR22 [4422] D37	16mm	8000	
	TA 4, CAR84 [4484]	18mm / 22mm / 24mm	1842 / 8090 / 1908	
	TA6, CAR89, CAR11 [4489] D51	17mm / 18mm / 25mm	8018 / 1903 / 1538	
	TA6, CAR89, CAR11 [4489] D54	18mm / 25mm	1904 / 1539	
	TPC CAR26 [4426]	20mm / 25mm / 28mm	1896 / 1619 / 1618	
	TPC CAR20 [4420] D61	17mm; 24mm; 28mm; 30mm	8033; 3277; 3279; 3278	
	PNP0084x379		8045	
	PNP4417x550		8011	
	PNP4488		8043	
	PNR4423x600		4912	
	PNR4423x650		4916	
	AP Racing	CP2195 D38 LD19 see historic catalogue	10.5mm	1362
		CP2270 D46	17mm	1269
		CP2279 D50	17mm / 20mm / 22.5mm	1361 / 1270 / 1272
CP2340 D40 / D48		16mm	1749 / 1265	
CP2372 D52		16mm	8040	
CP2399 D43 LD20		15mm	1363	
CP2712 D44		15mm	8068	
CP2749 D66		20mm / 25mm	1218 / 1220	
CP3215 D42		17mm	2126	
CP3345 D44		16mm	2127	
CP3558 D51		28.5mm	8192	
CP3558 D46 / D51 / D54		25mm	1813 / 1538 / 1539	
CP3714 D54		28.5mm	8192	
CP3894 D46 / D51 / D54		18mm	1852 / 1903 / 1904	
CP4479 D42		17mm / 18mm	2126 / 8216	
CP4479 D50		20mm / 22.6mm	1270 / 1272	
CP5045 D61		18mm / 22mm	1842 / 8090	
CP5070 D51		17mm	8018	
CP5119 D50		15mm	1587	
CP5510 D43		22mm / 20mm / 16mm	8193 / 1283 / 1705	

Make	Race Caliper	Pad Thickness	Part. Nr.
AP Racing	CP5788 D48	20mm	1896
	CP5820 D61	17.5mm / 24mm / 28mm / 30mm	8033 / 3277 / 3279 / 3278
	CP5820 D62	30mm	2016
	CP6070 D49	25mm	1674
	CP6080 D54	29mm	2557
	CP6210 D54	25mm / 26.5mm / 29mm / 31mm	8222 / 2688 / 2557 / 2558
	CP6210 D64	29mm	2560
	CP6230 D54	25mm	8222
	CP6268 D62	30mm	2017
	CP6276 D62	30mm	2019
	CP6470 & CP6480 D49	25mm	1674
	CP6600 D55	16.7mm	4345
	CP6627 D51	16.7mm	8214
	CP6766 D50	18mm	8044
	CP6820 D46	16mm	1617
	CP7031 D32 (new F3 caliper)	16mm	8060
	CP7040 D58	16.7mm	4346
	CP7600 D46	14.4mm / 16mm	8076 / 4349
	CP8250 D41	20mm	2205USA
	CP8250 D51	20mm	2206
	CP9660 D54	18mm	1904
	CP9665 D54	25mm	8222

Brakeman	F1 Tornado		1362
	F2 Tornado		1363
	F4 Tornado		2555

Brembo	07.1715. [type „62“ family]	15mm / 18mm	4304 / 2723
	07.4180.	15mm	1587
	07.4865. GT (F-40) [caliper family B, H, P]	18mm	1287 / 2179
	07.5064. [type „100“ family]	20mm / 16mm / 22mm	1283 / 1705 / 8193
	07.5139. [type „132“ family]	16 / 20 / 22 / 25 / 26.5 / 29 mm	1595 / 1607 / 8037 / 1674 / 2704 / 8191
	07.5146. GT (Lotus) [caliper family A, C, F]	15mm	1408
	07.5169. [type „140“ family]	16 / 17 / 20 / 25 / 28mm	1616 / 8030 / 1896 / 1619 / 1618
	07.5684. 8 piston [type „80“ family]	20mm	2053
	07.5868. 8 piston	20mm / 22mm / 26.5mm	2484 / 2105 / 2782
	07.6955.1 [type „140C“ family]	17.5mm / 24mm / 28mm / 30mm	8033 / 3277 / 3279 / 3278
	07.7293. 6 piston [type „164“ family]	20 / 22 / 25 / 29 / 31mm	2687/8038/8087/2488/8173
	07.7881. 4 piston [type „100A“ family]	16mm	8000
	07.8544 8 piston [caliper family G]	16.5mm	2931
	07.A262.xx (new) F3	16mm	8049
	hp 2 piston 84.7x70		8069
	hp 4 piston 125x65		8023
	hp 6 piston 165x82		8005
	XA3.40.xx 6 piston [type „164B“ family]	18mm	8044
	„Big Red“ [type „132A“ family]	18mm / 22mm / 24mm	1842 / 8090 / 1908

Please check with the appropriate drawing!

Make	Race Caliper	Pad Thickness	Part. Nr.
Brembo	XA5.71.M2 6 piston D48 [caliper family M]		8061
	XA5.71.L2 6 piston D57.5 [caliper family J, N]		8062
	XA5.71.xx 6 piston D66		8081
	XA5.71.xx 6 piston D76		8083
	XA5.71.xx 6 piston D85		8091
	racing 6 piston D64	21 / 25 / 26 / 29 / 31mm	8102 / 8101 / 8194 / 8100 / 8103
	NASCAR front 07.7614 [type „B23“ family]	30mm	2016
	NASCAR front 07.7614 bigger version [type „B21“ family]	30mm	2017
Caparo AP	racing caliper		8078
Coleman	Series I & II		2555
	Series III		1595
	Series IV		1903
Lucas/	14LF		3190
Girling	16/4		1203
	18/4 RRS-19 18/4 RRS-25		1267 / 1268
	SL 38/43		1361
	D 12/14 R		3102
Outlaw	1000 / 1500		1809USA
	2000 / 2500		1796
	3000 / 3500 / 4000		2555
PFC	ZR20 [Formula 3]		8034
	ZR22 4 piston		8093
	ZR27 4 piston (BMW M235i Racing)		8197
	ZR53 6 piston [D52]		4923
	ZR53 6 piston [D59.5]		8092
StopTech	ST21		4304
	ST22		1587
	ST40		1204
	ST43 standard annulus		2205
	ST43 wide annulus		2206
	ST60		1903
	STR GT	17.5 / 24 / 28 / 30 mm	8033 / 3277 / 3279 / 3278
Wilwood	Dynalite Centre Pin		1796
	Dynalite Single		1809USA
	Dynalite Single 6812DR31		6812USA
	GT	20mm / 25mm	1218 / 1220
	GT 4000		1607
	Integra IP		1619

Make	Race Caliper	Pad Thickness	Part. Nr.
Wilwood	Integra HP		2020USA
	IR - GT		1283
	Superlite	17mm / 20mm	8195 / 2555
	Superlite bridge bolt	D43	2205USA
	Superlite bridge bolt	D51	2206
	NDL		1712USA
	GM Metric [D154]		1594USA
	GMII, GMIII, [D52]		1595USA
	GN		1798USA

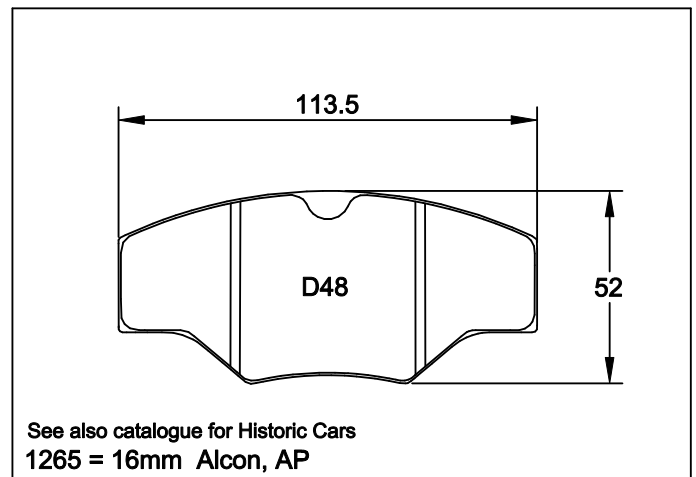
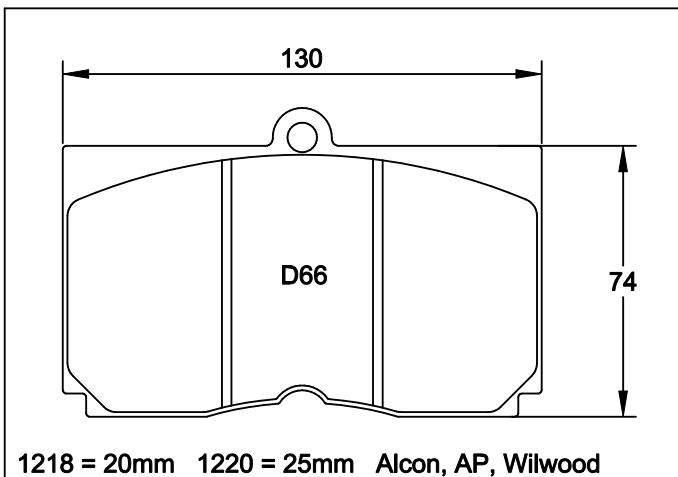
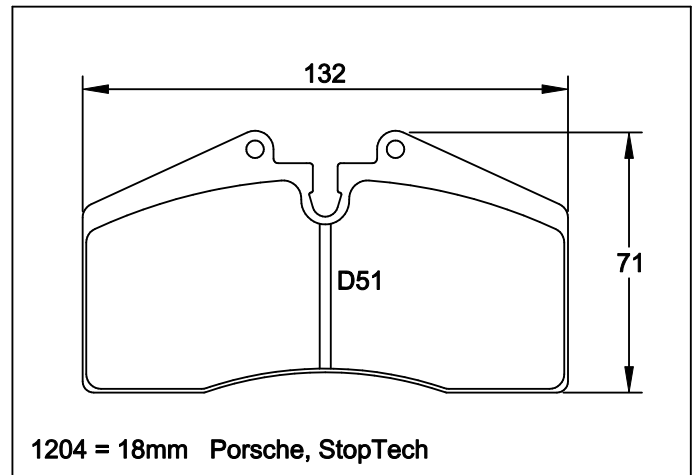
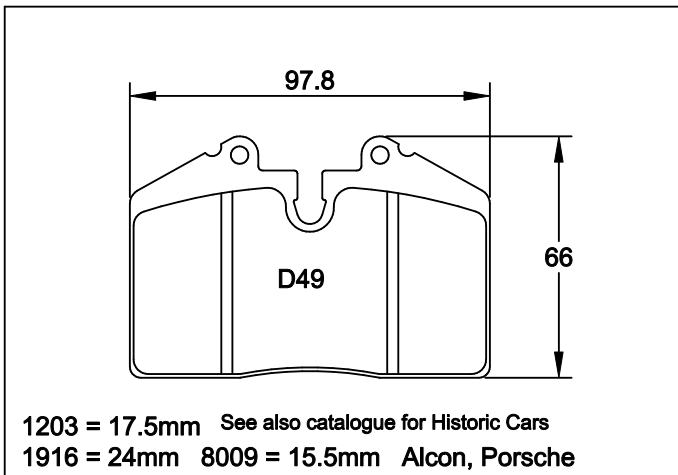
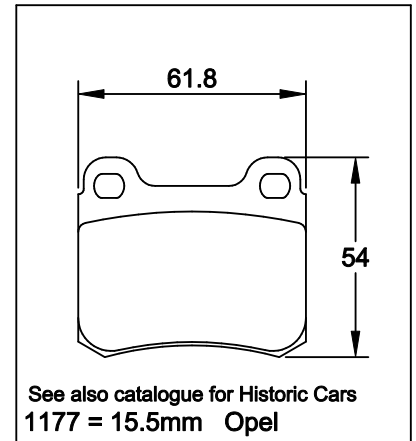
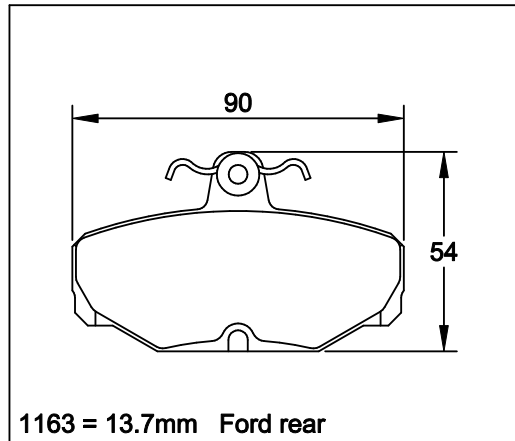
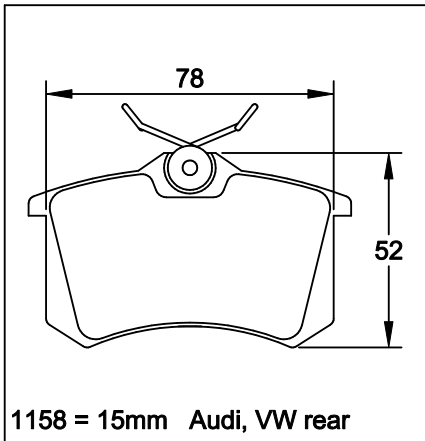
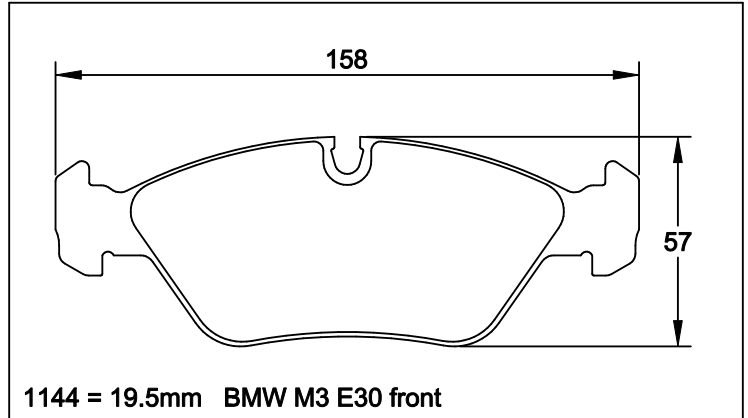
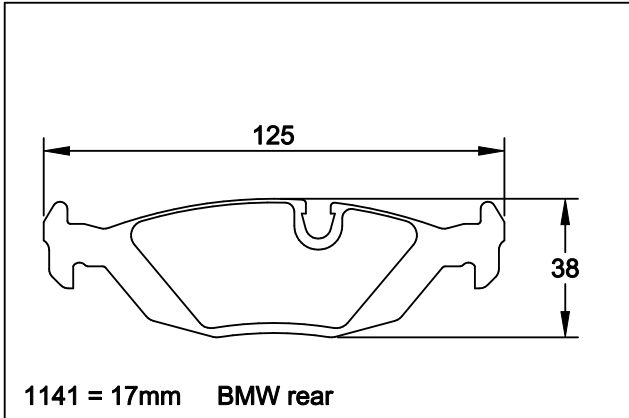

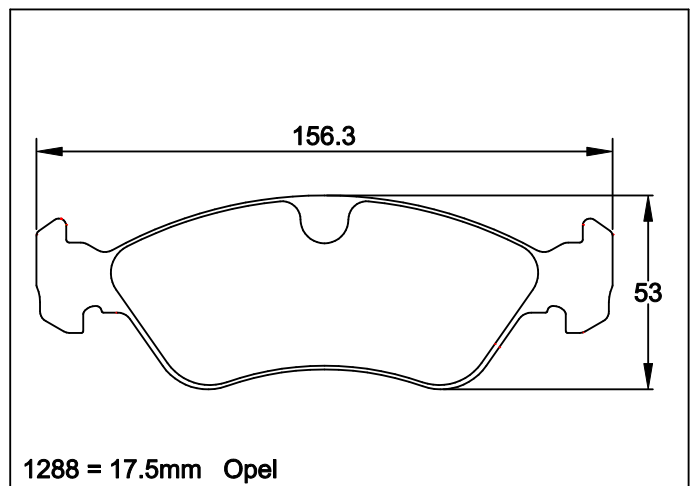
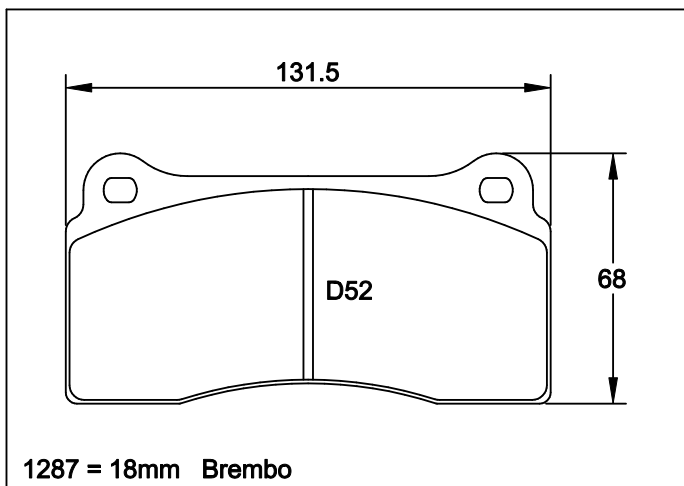
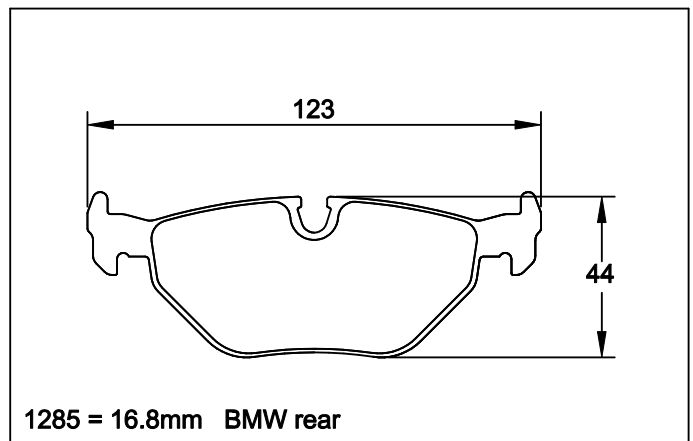
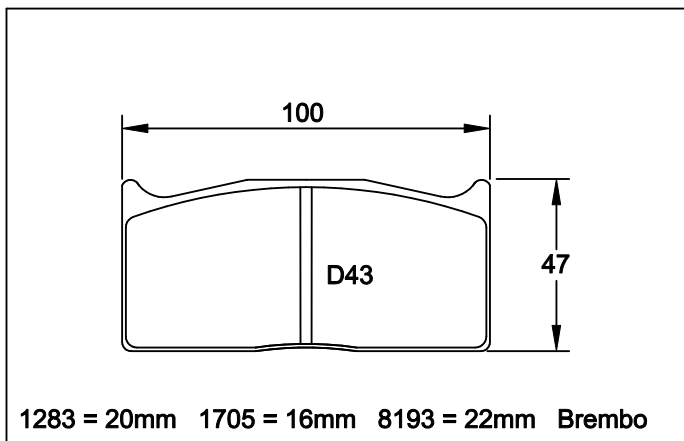
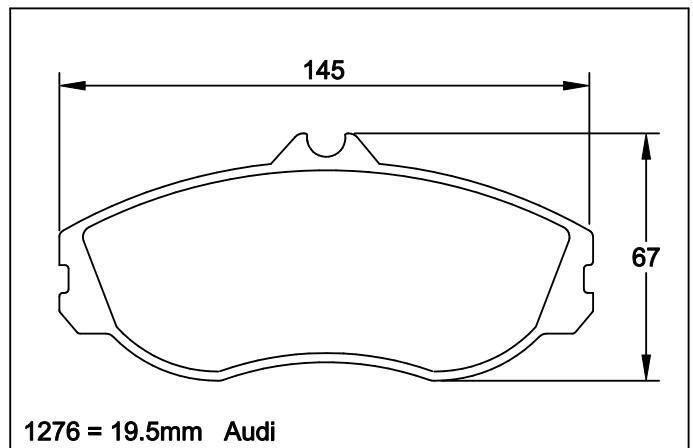
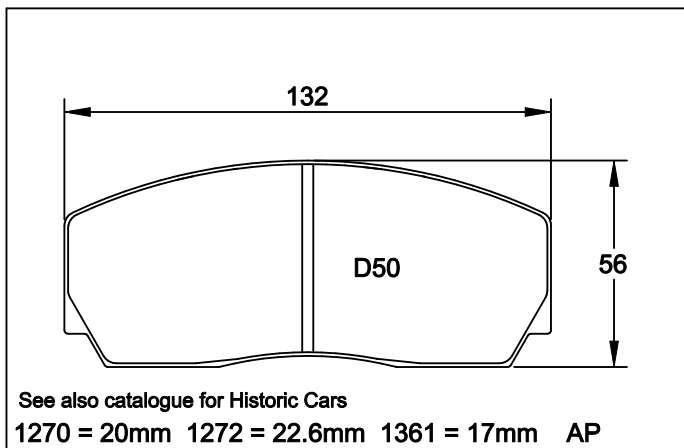
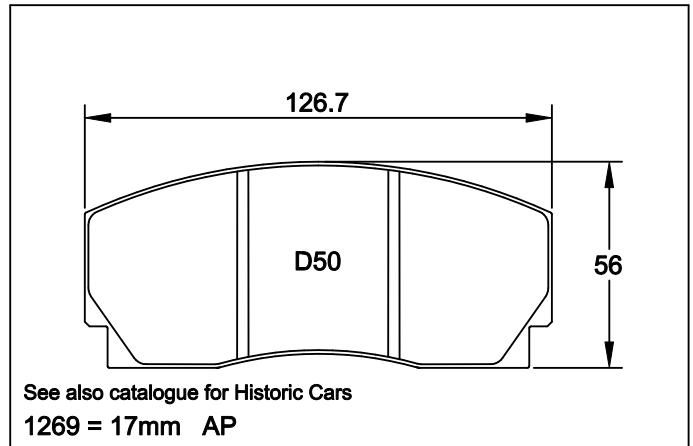
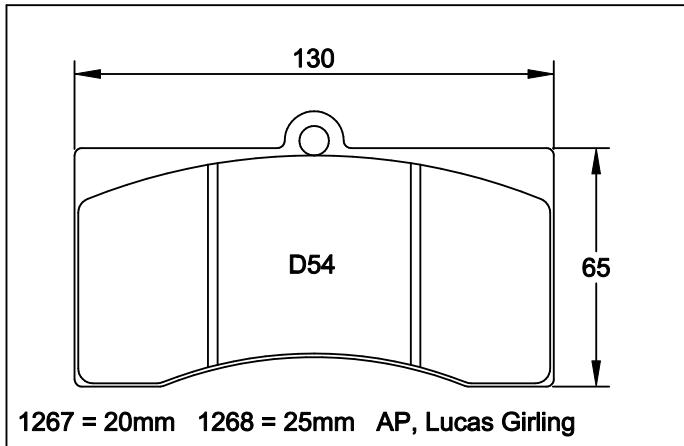

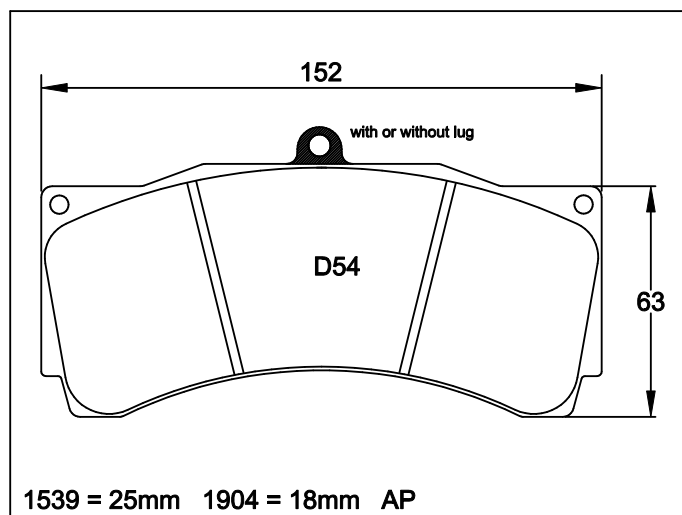
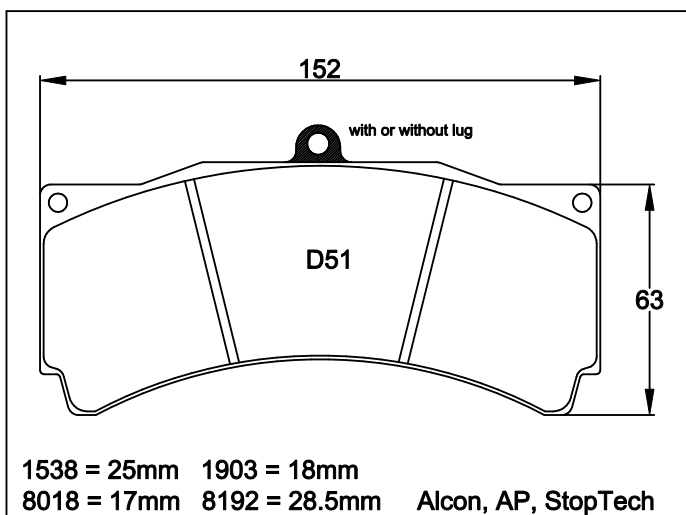
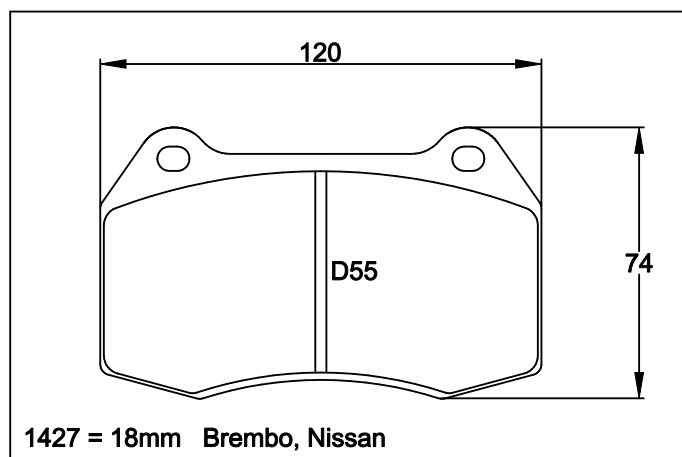
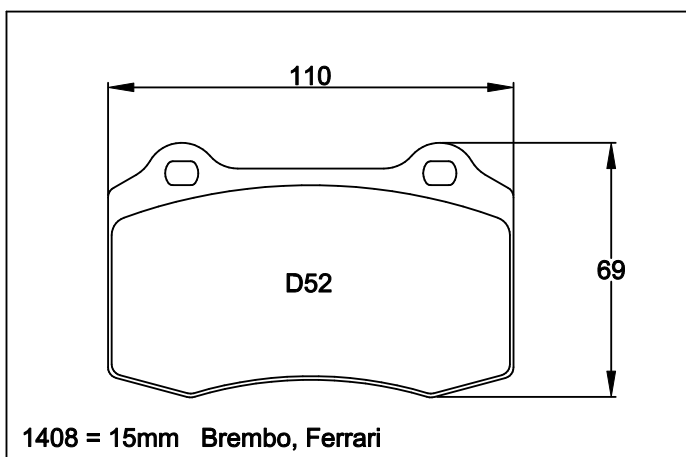
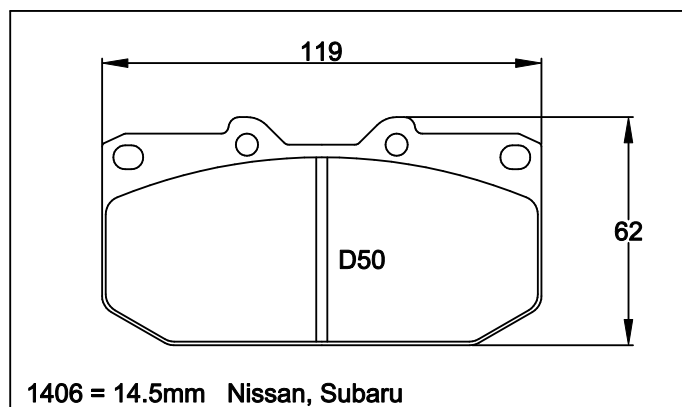
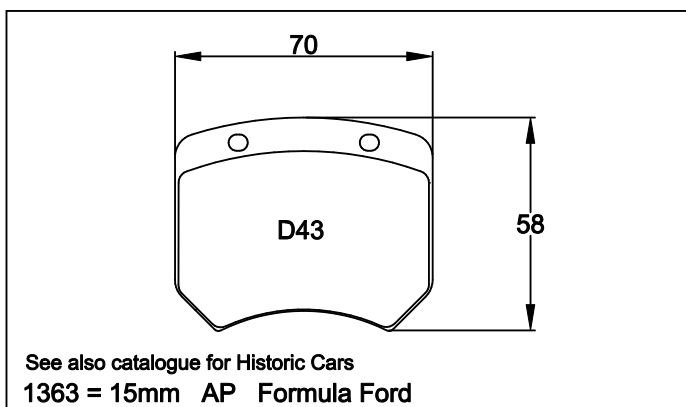
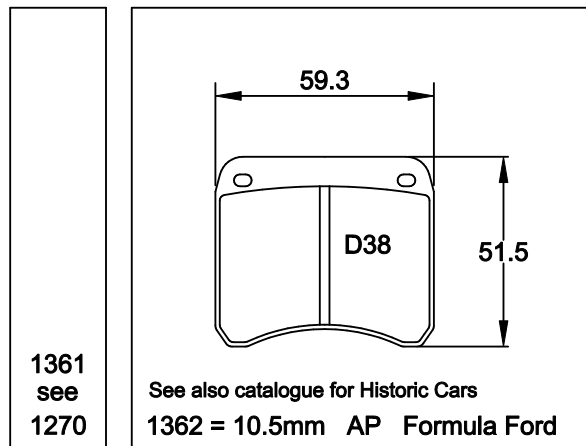
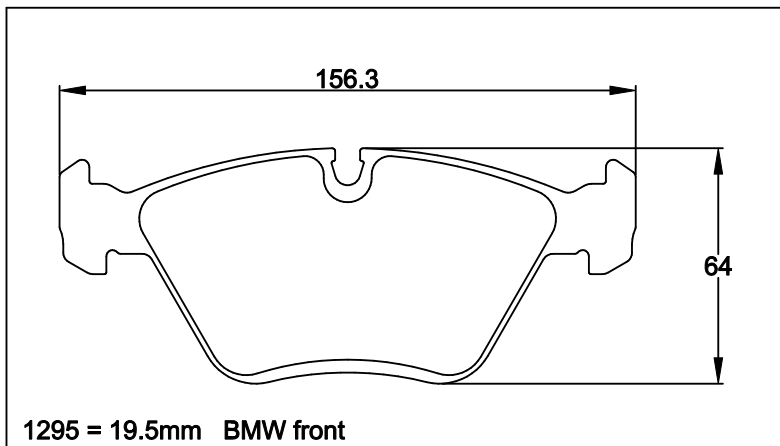

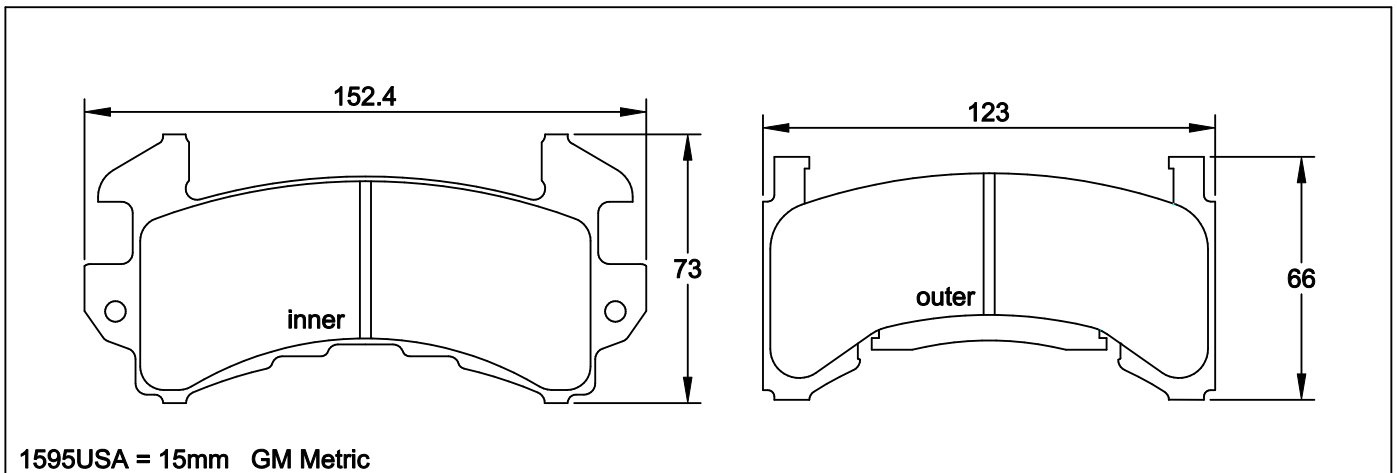
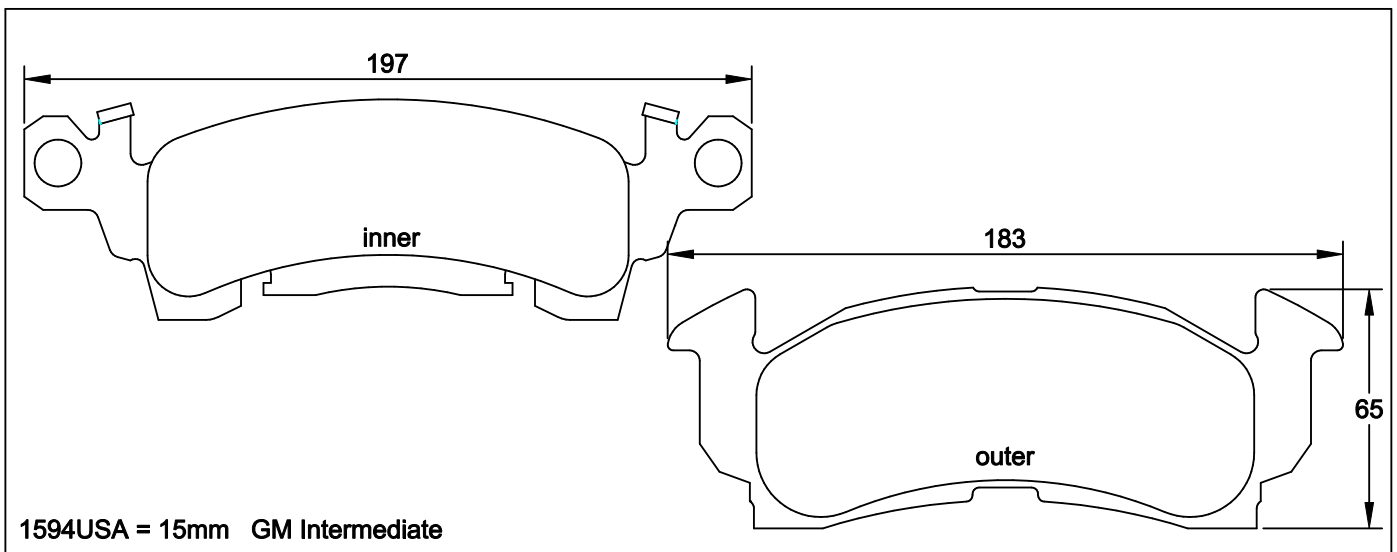
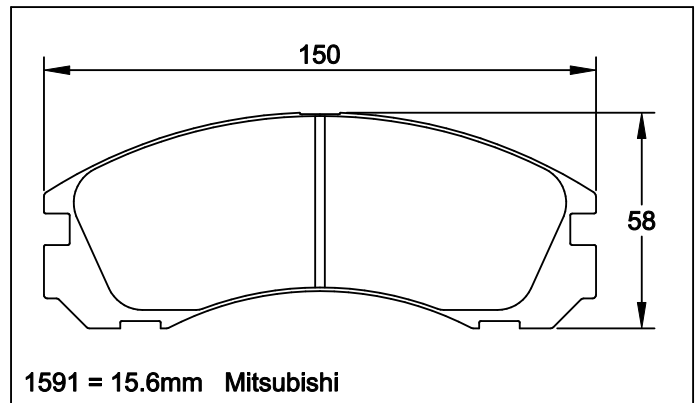
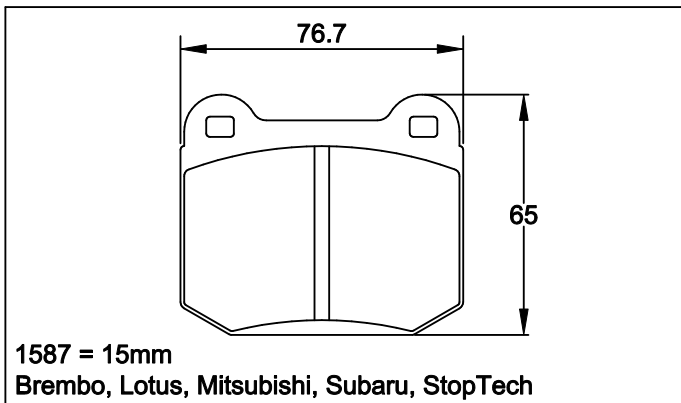
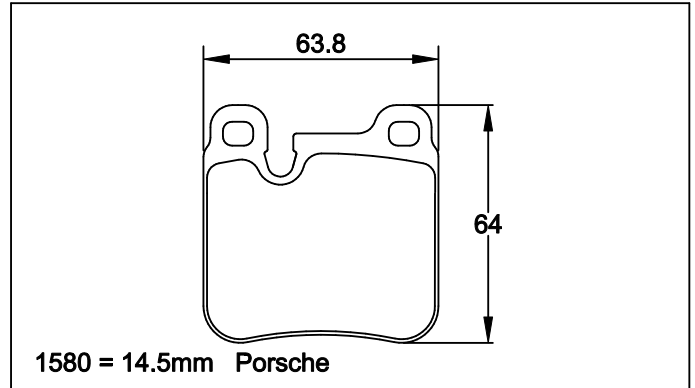
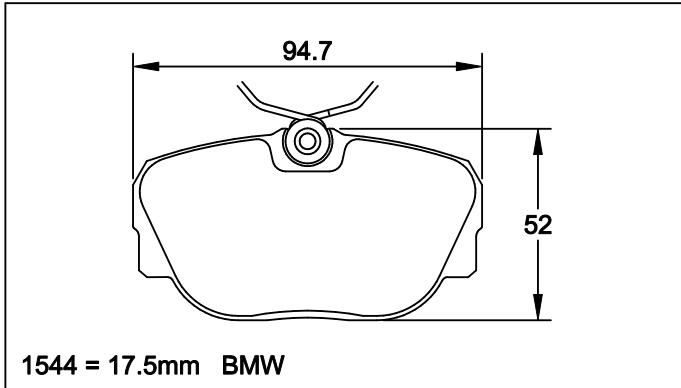

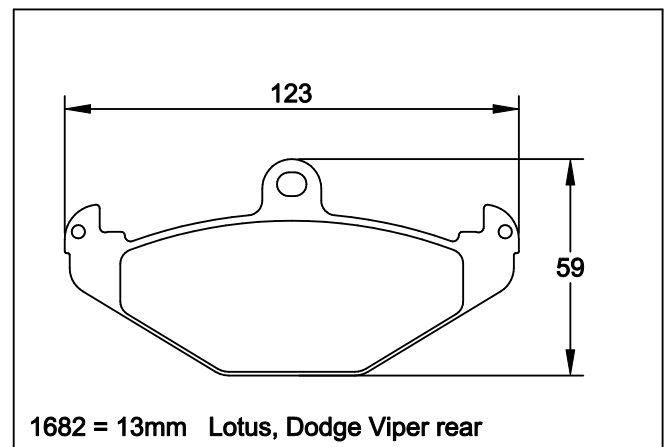
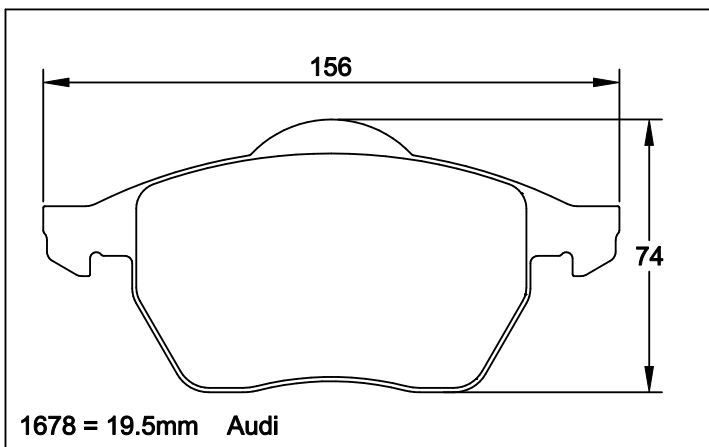
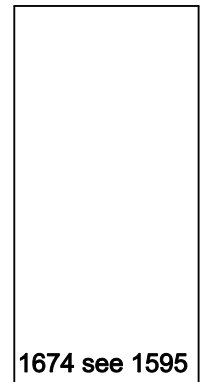
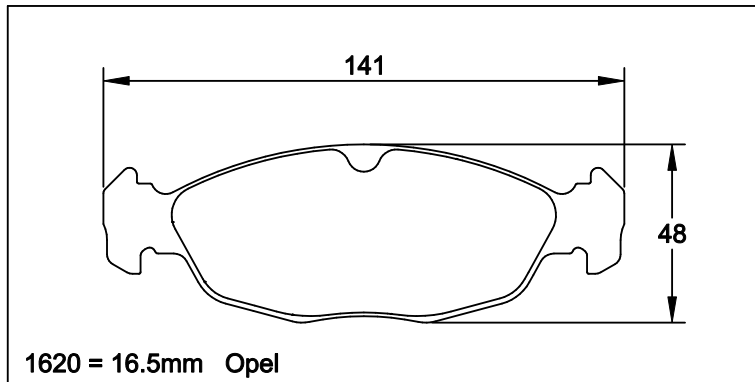
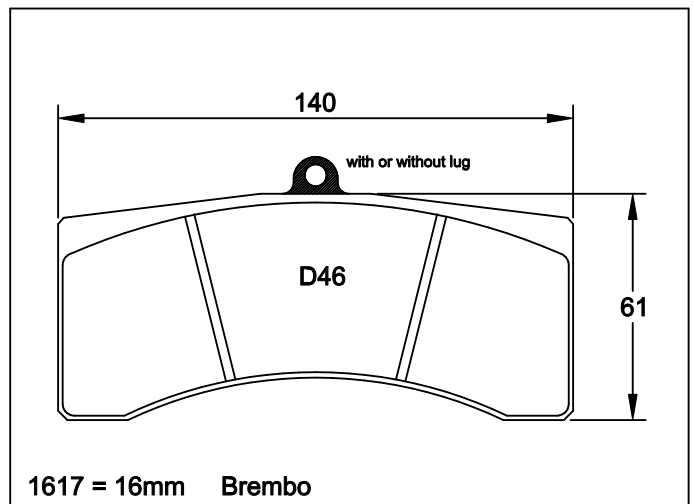
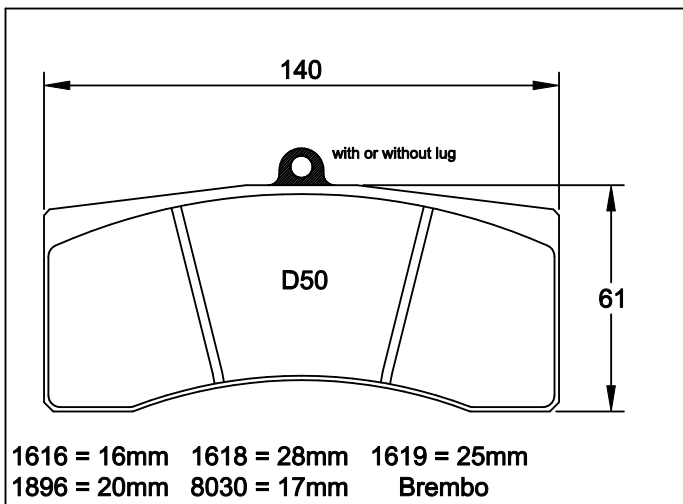
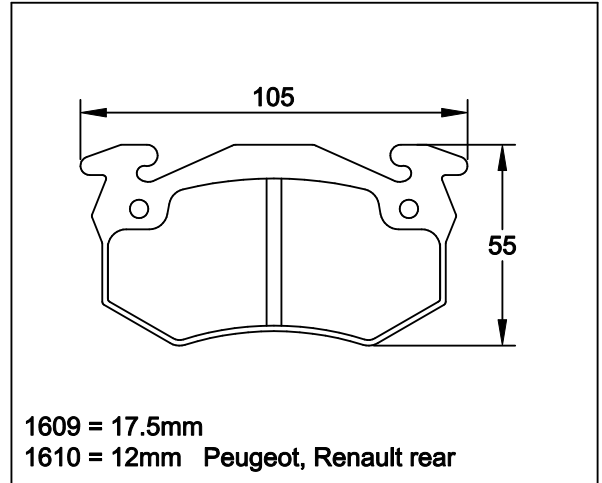
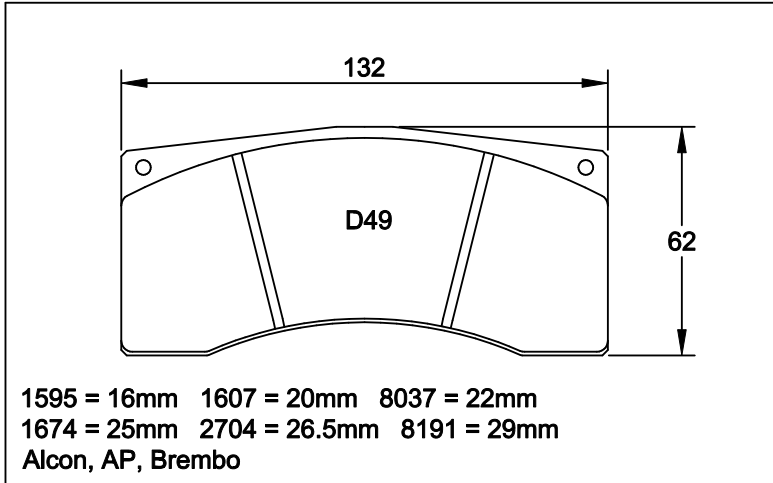

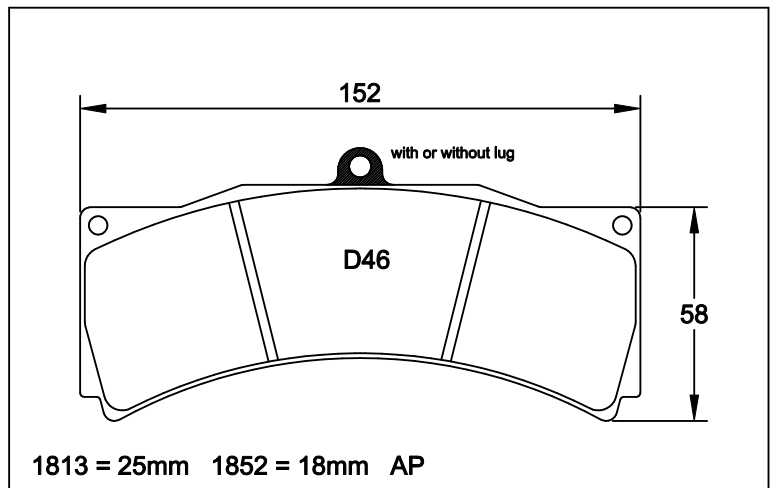
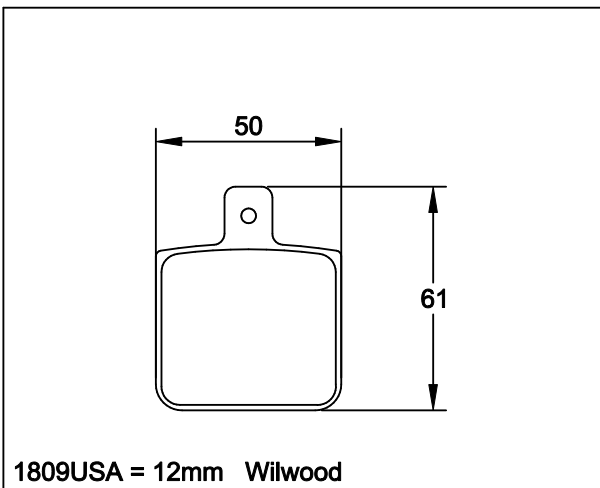
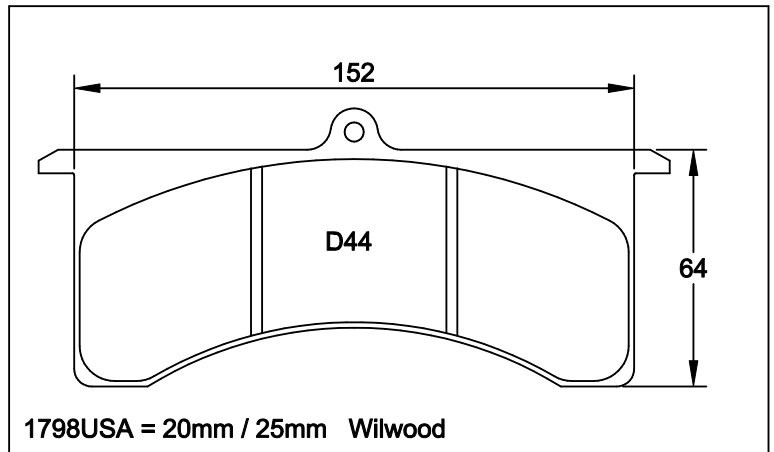
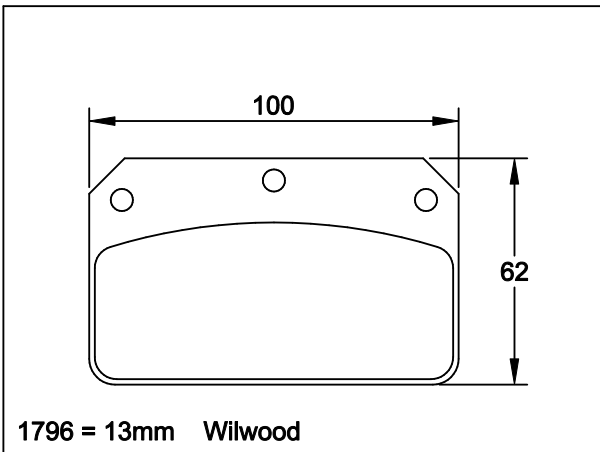
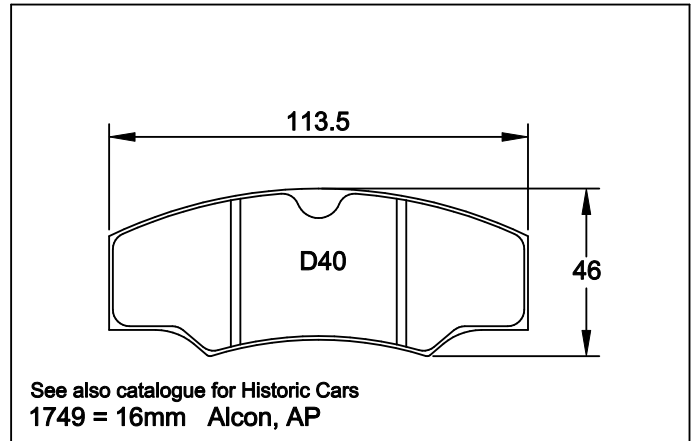
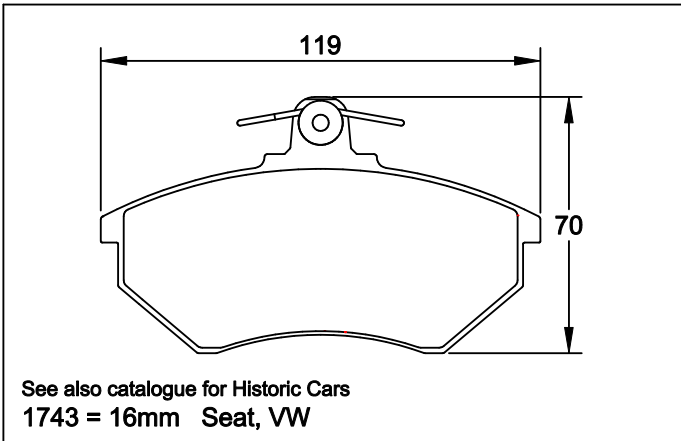
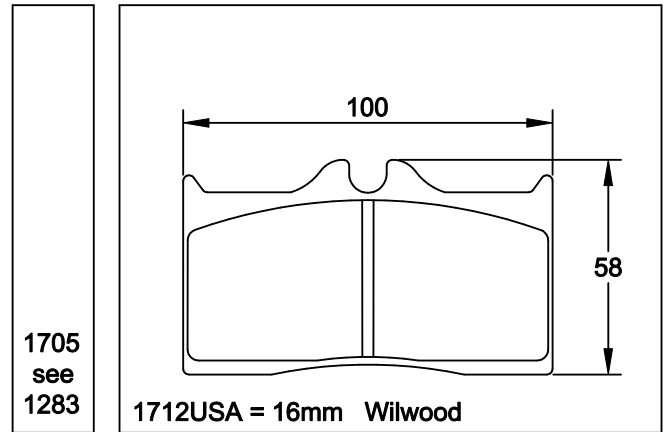
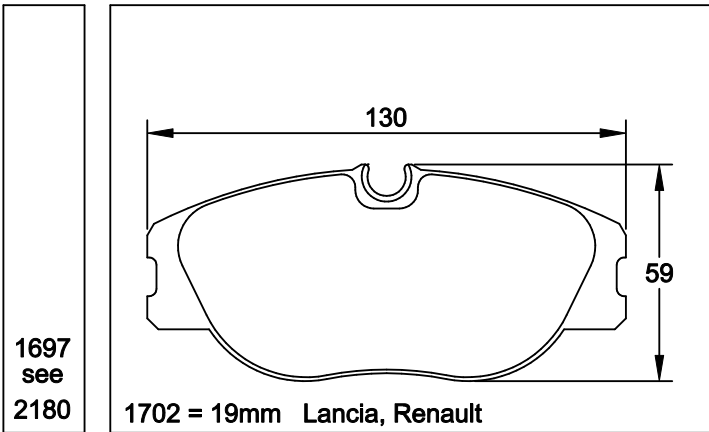

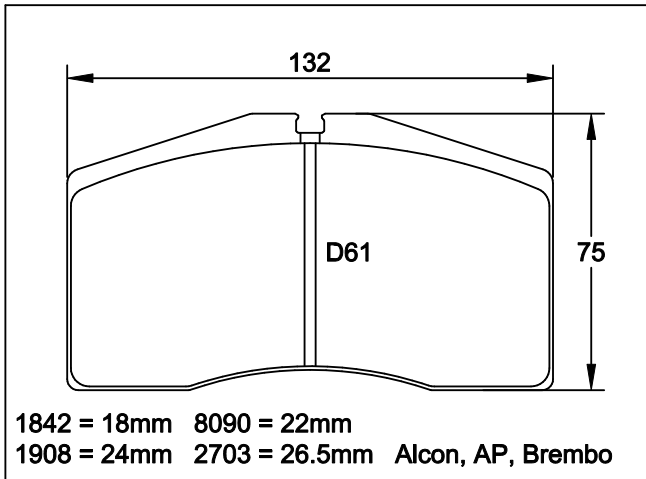

1852
see
1813

1896
see
1616

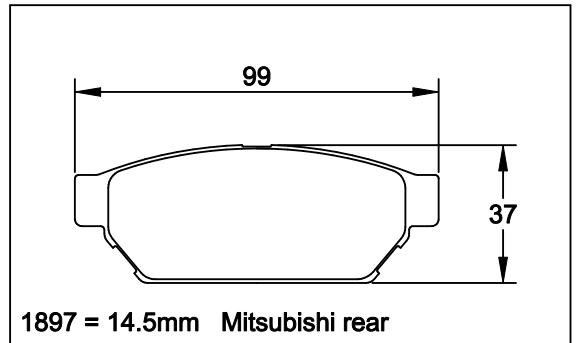

1903
see
1538

1904
see
1539

1908
see
1842

1916
see
1203

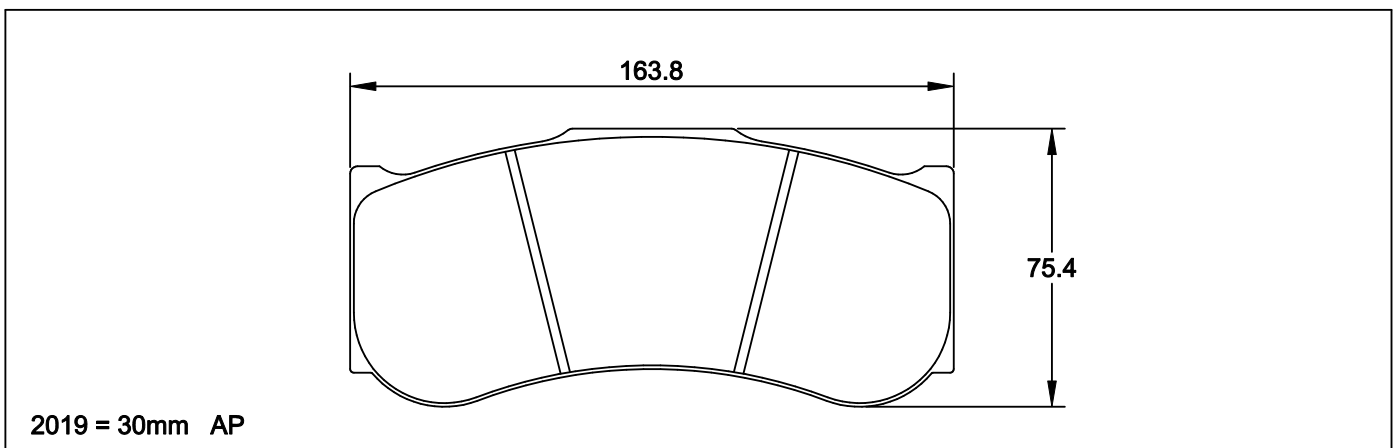
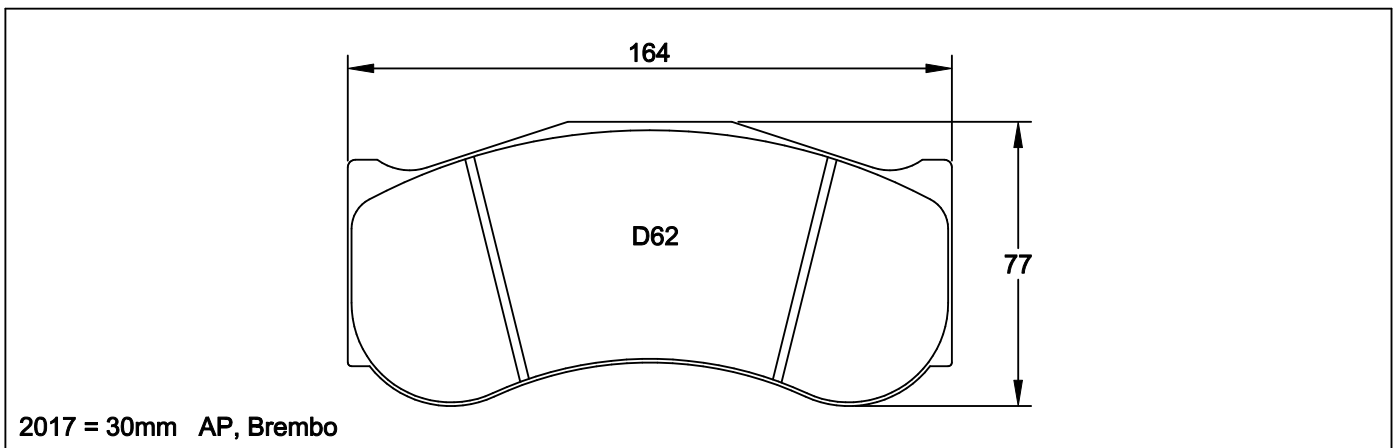
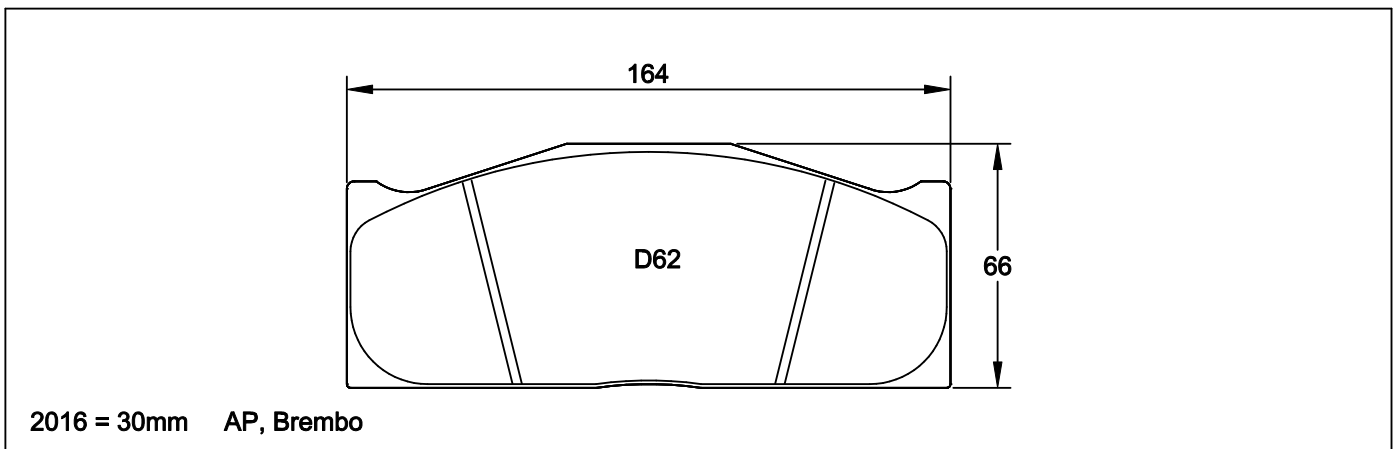

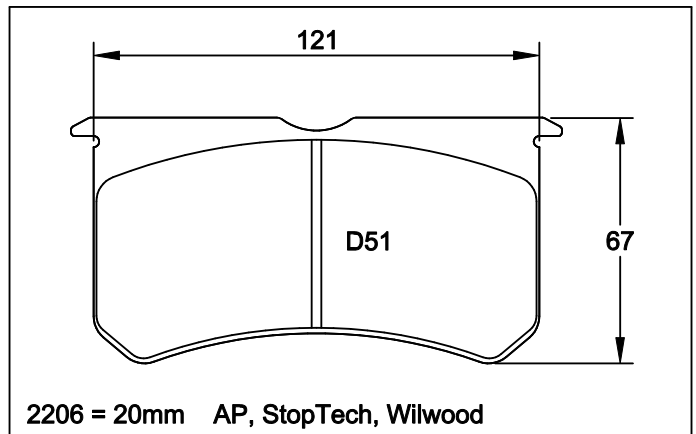
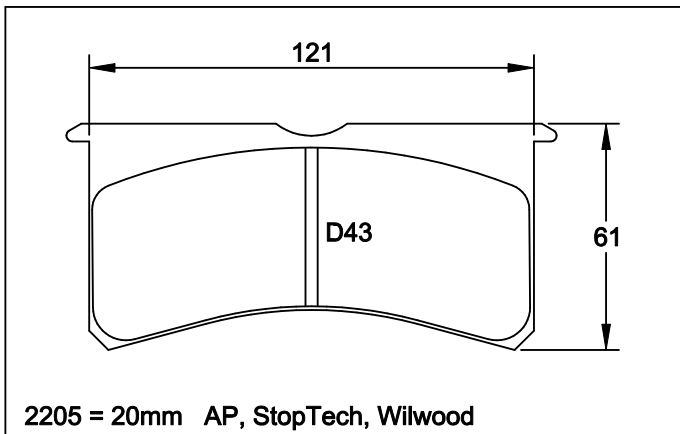
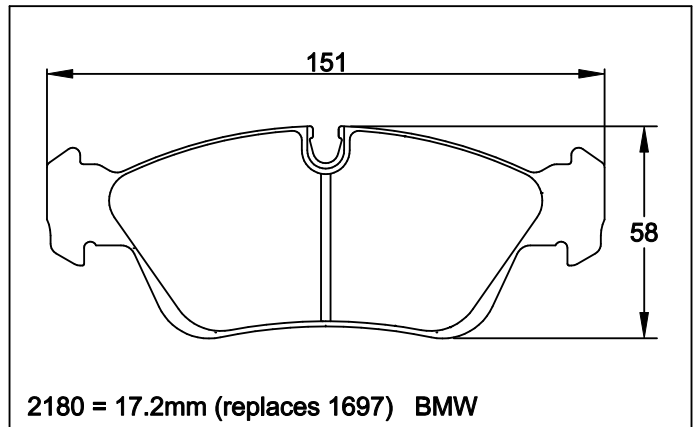
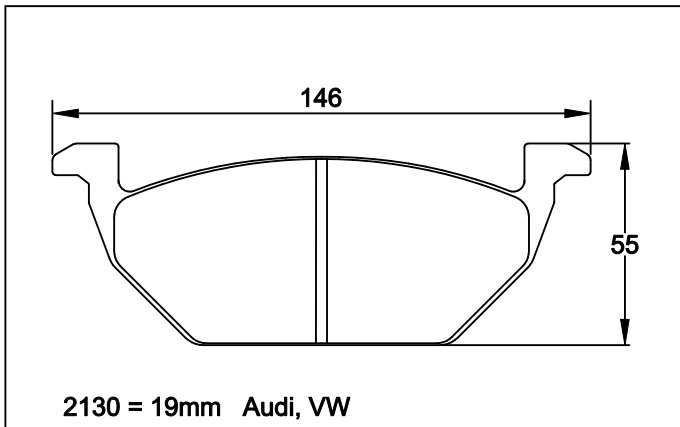
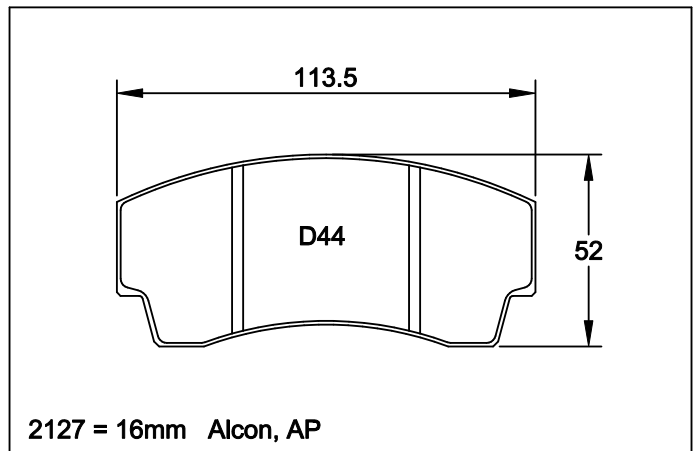
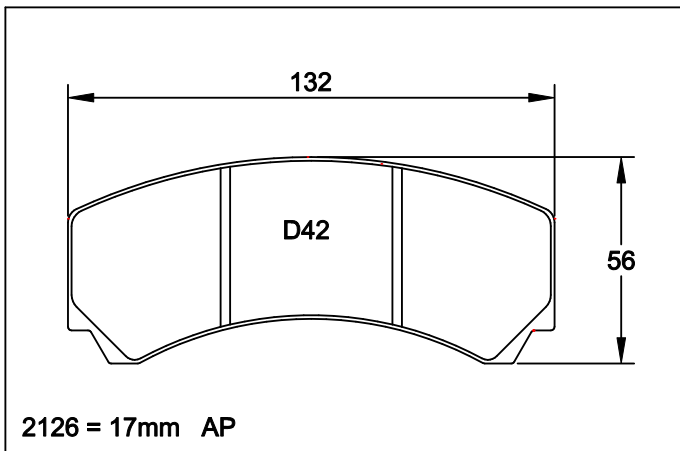
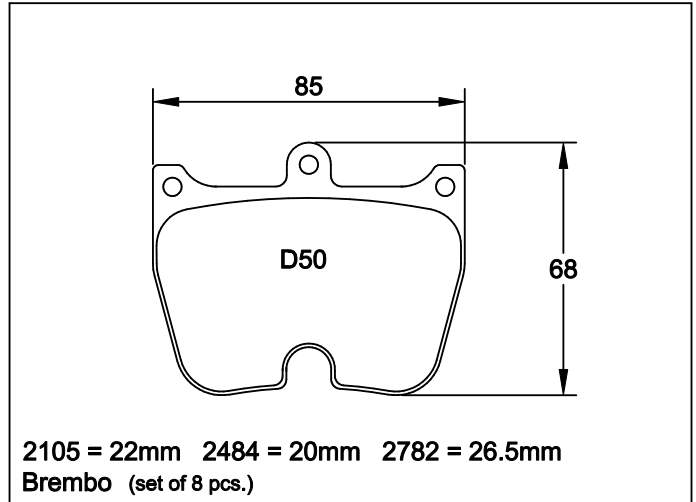
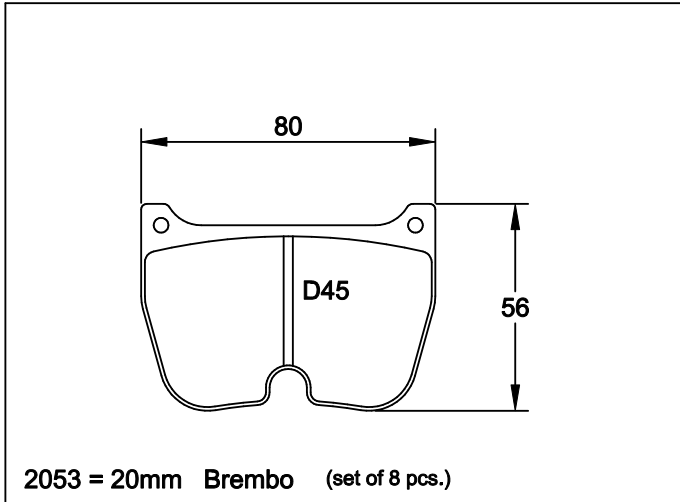

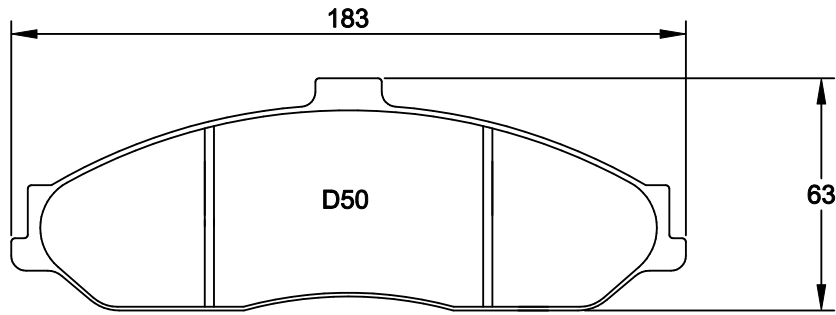

2213USA = 15mm Corvette C5, C6 base

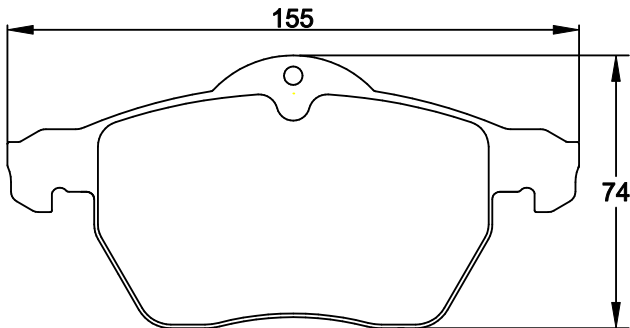

2275 = 19.5mm Opel

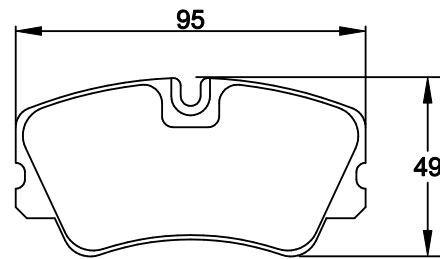

2388 = 18.5mm Citroen, Peugeot

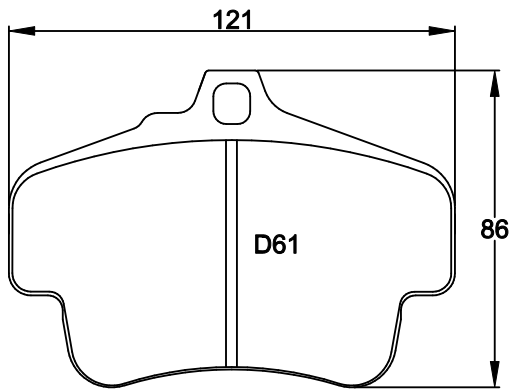

2405 = 18.5mm Porsche

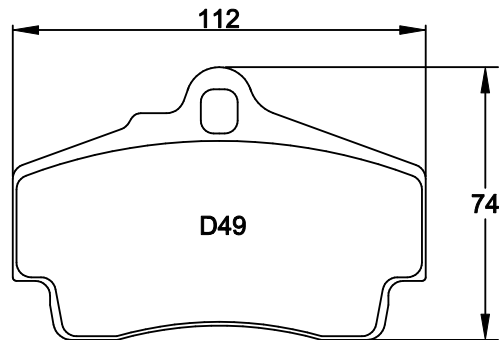

2406 = 15.5mm Porsche

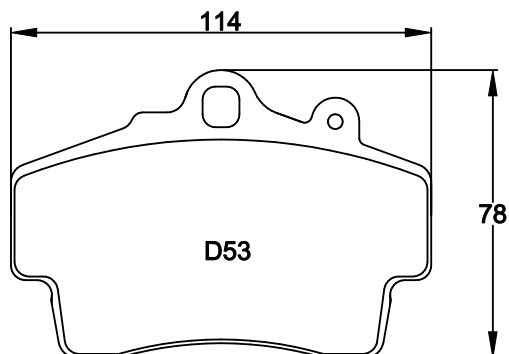

2407 = 15.5mm Porsche

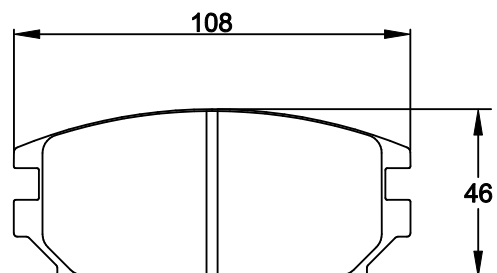

2445 = 15.5mm Mitsubishi rear

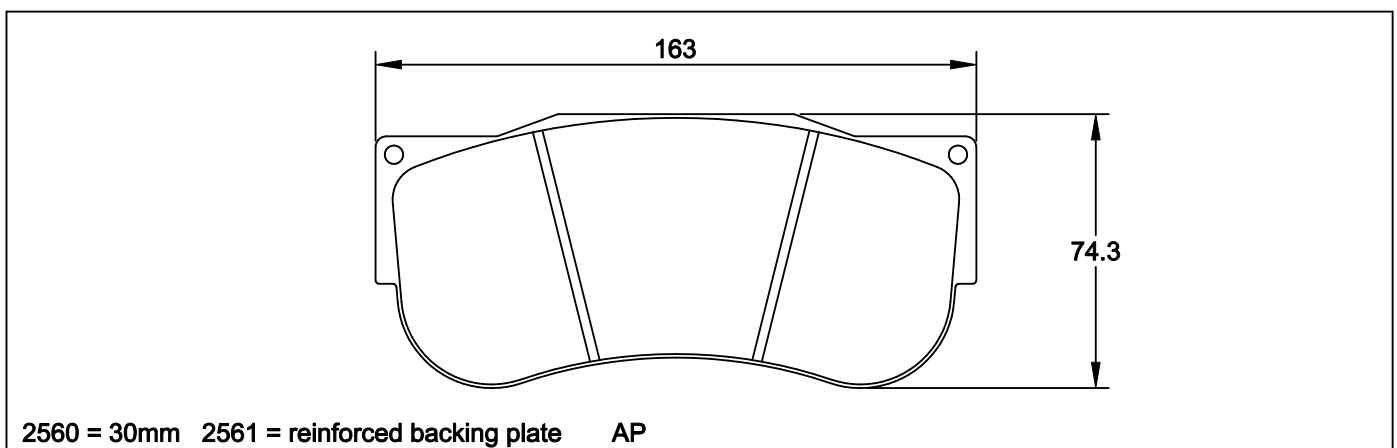
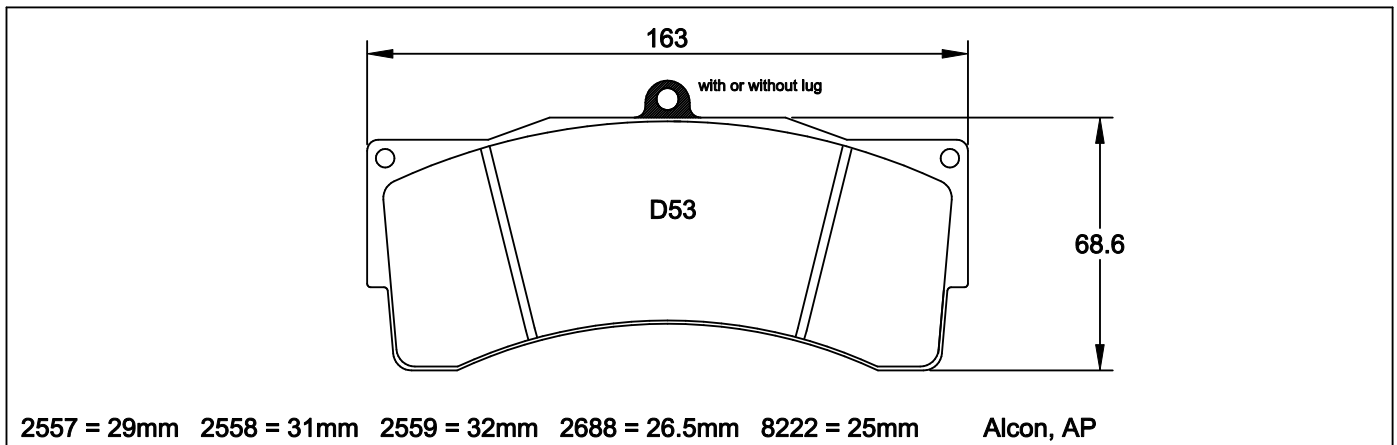
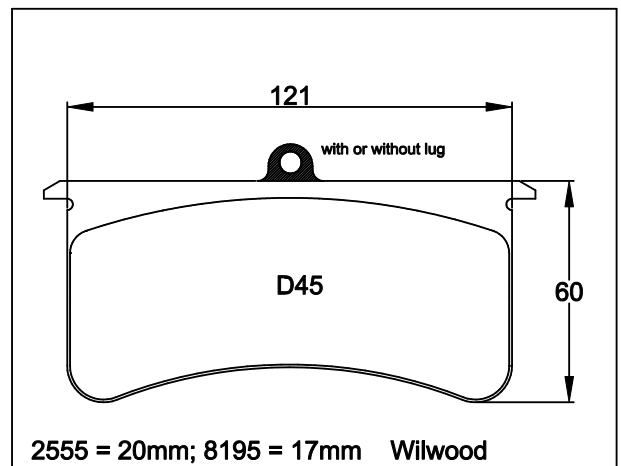
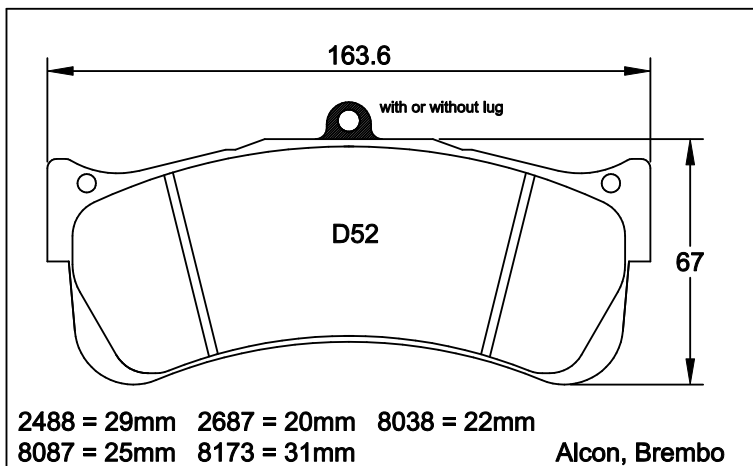
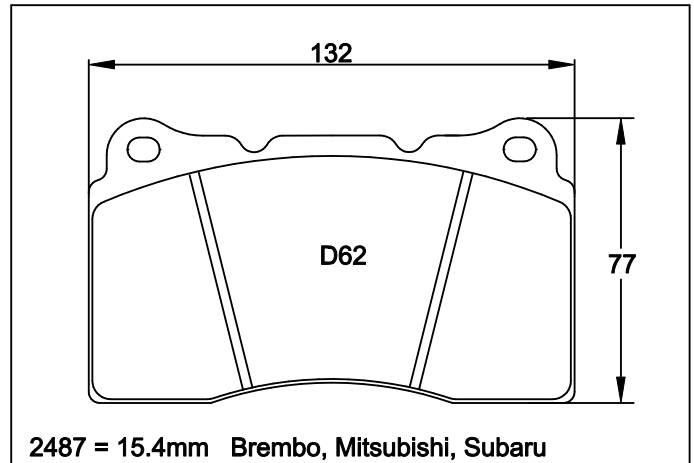
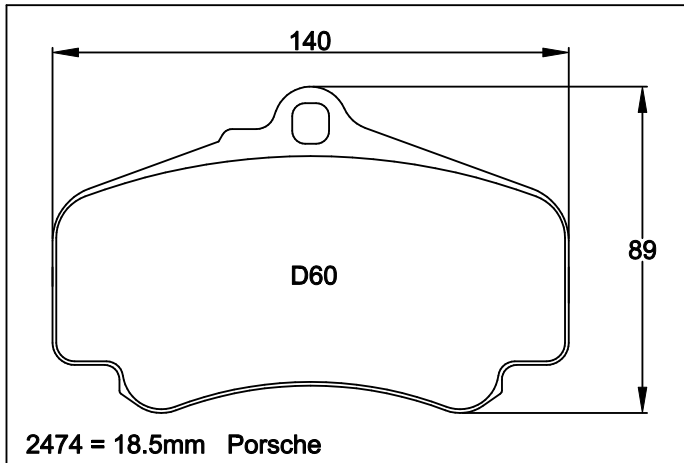

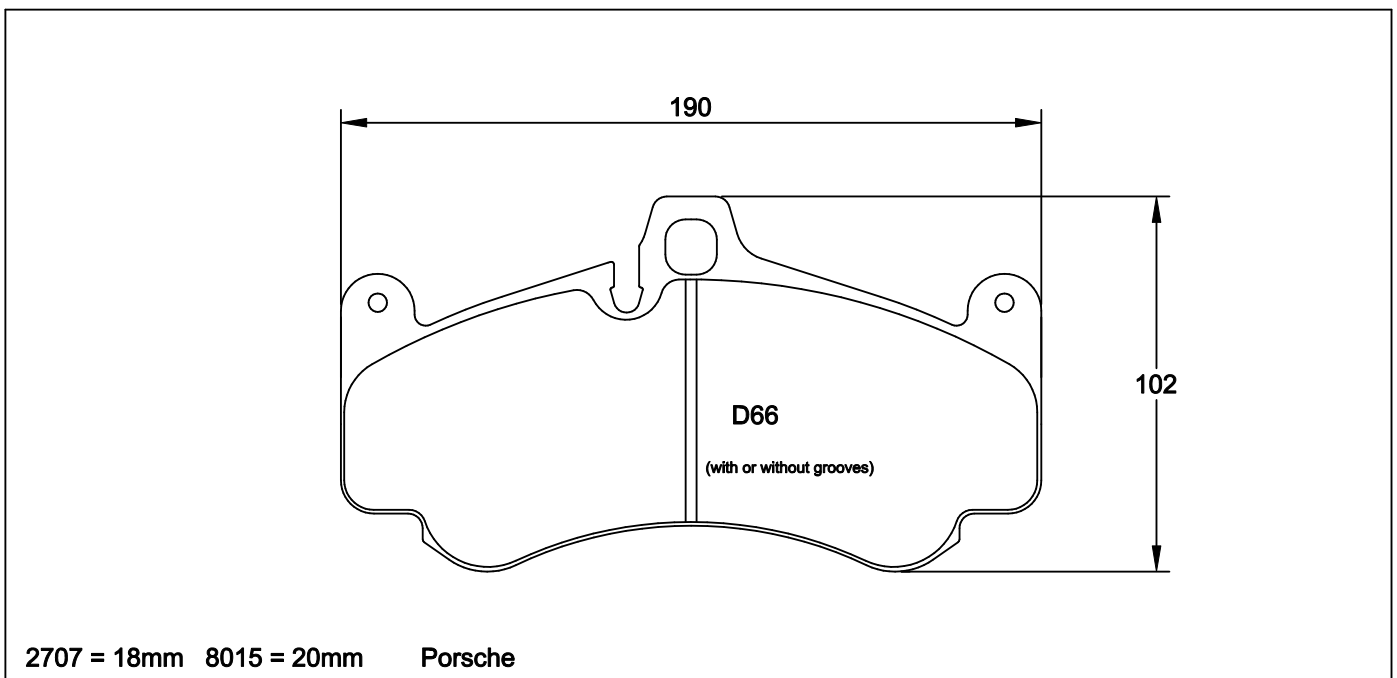
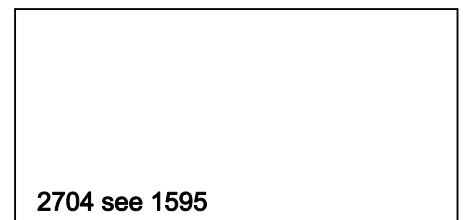
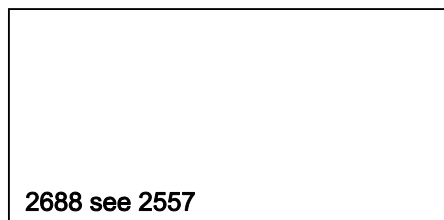
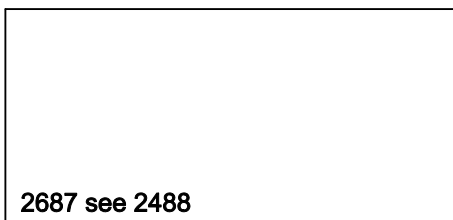
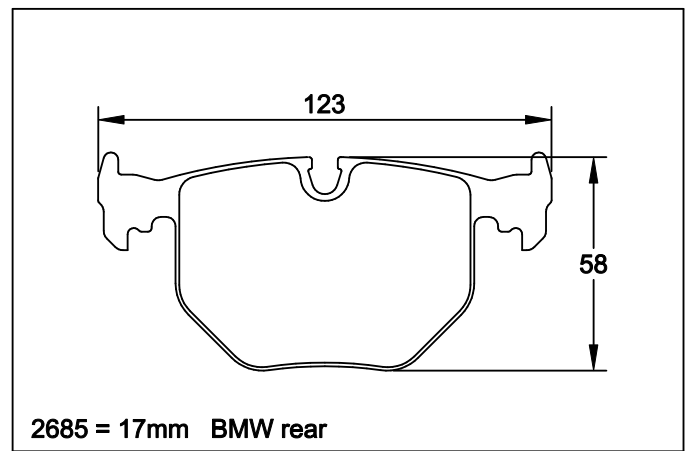
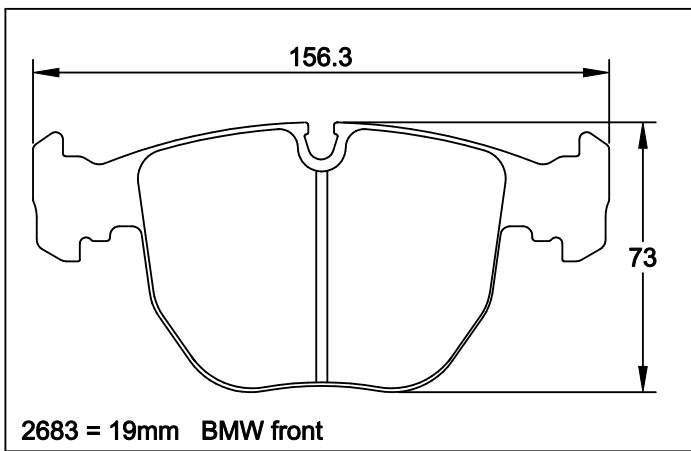
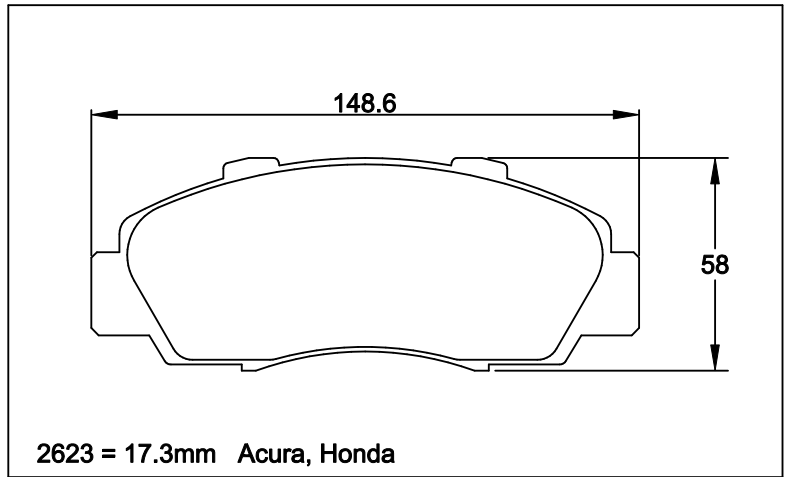
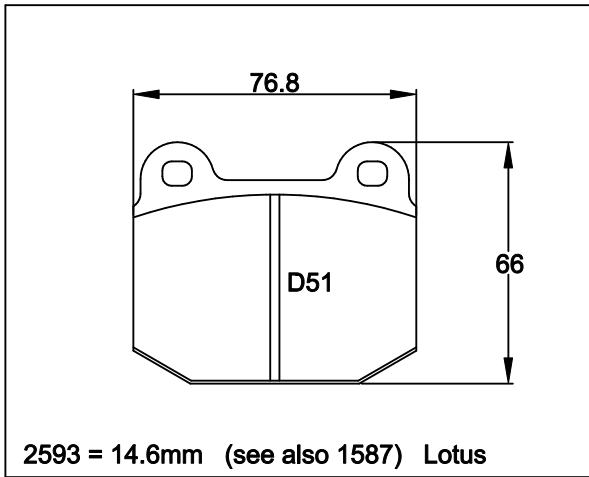

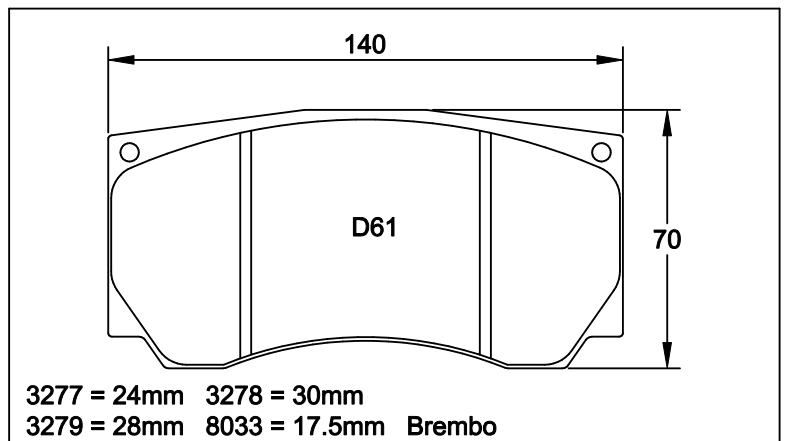
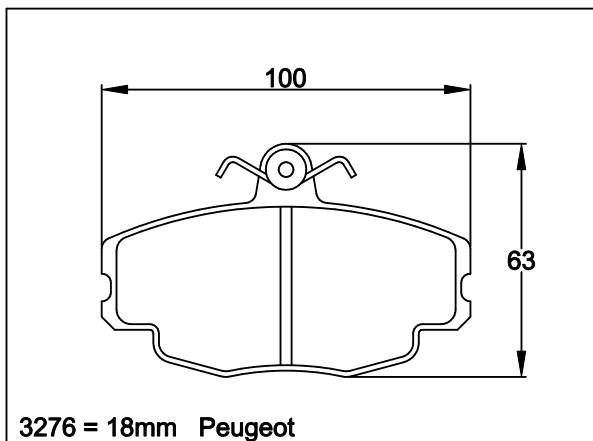
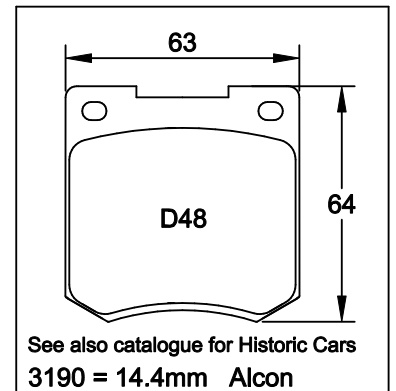
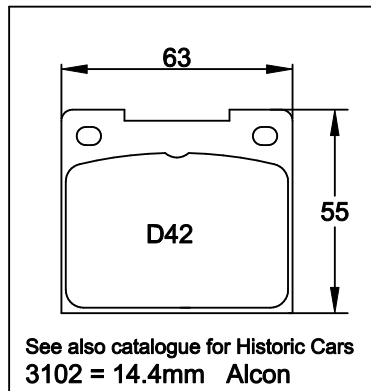
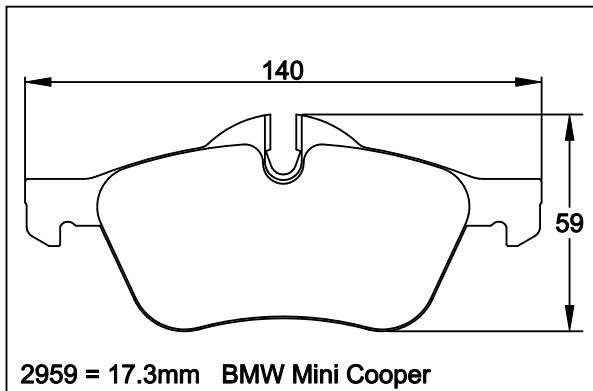
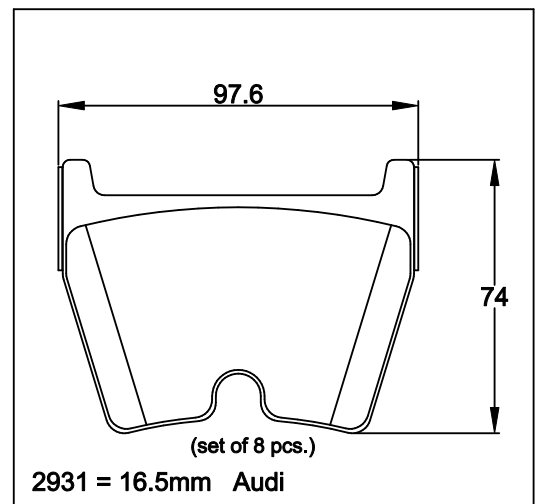
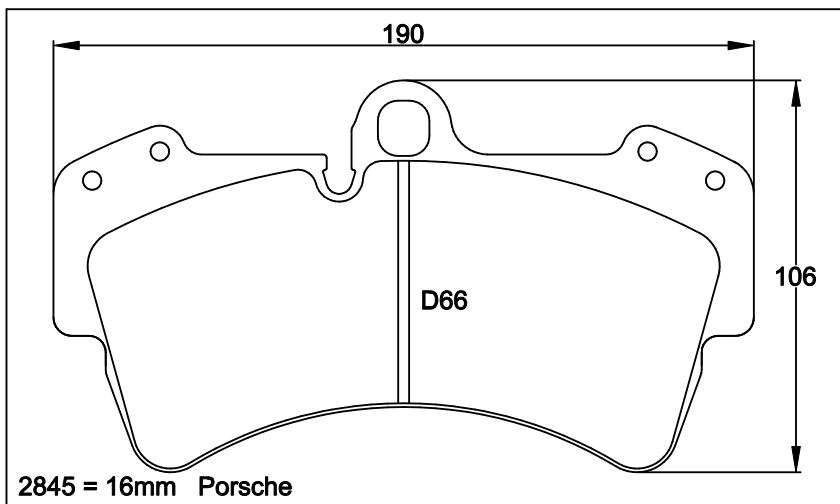
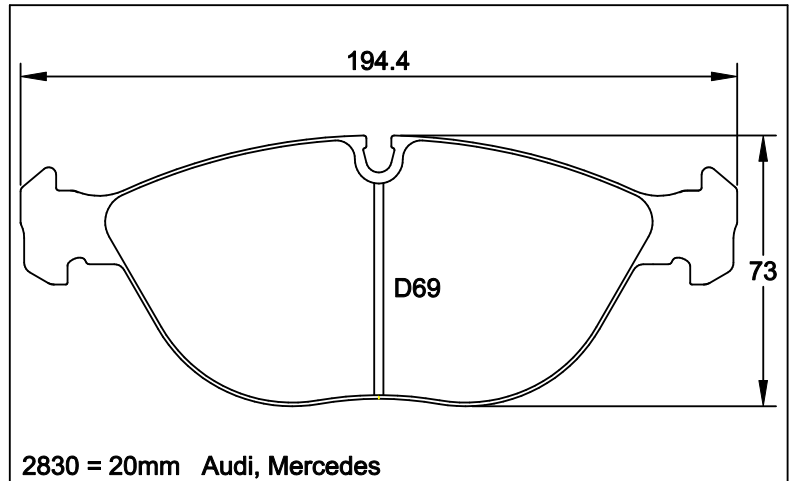
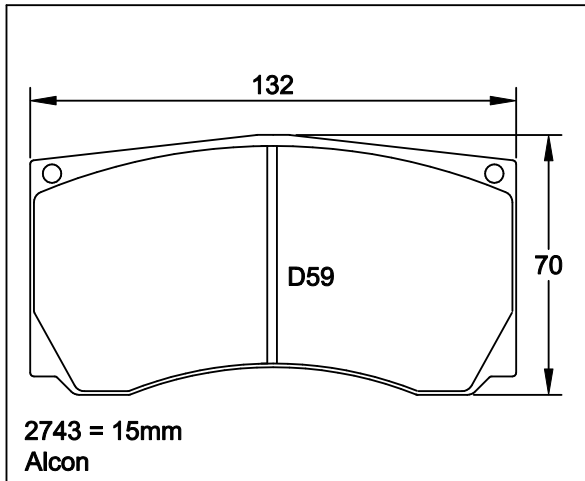

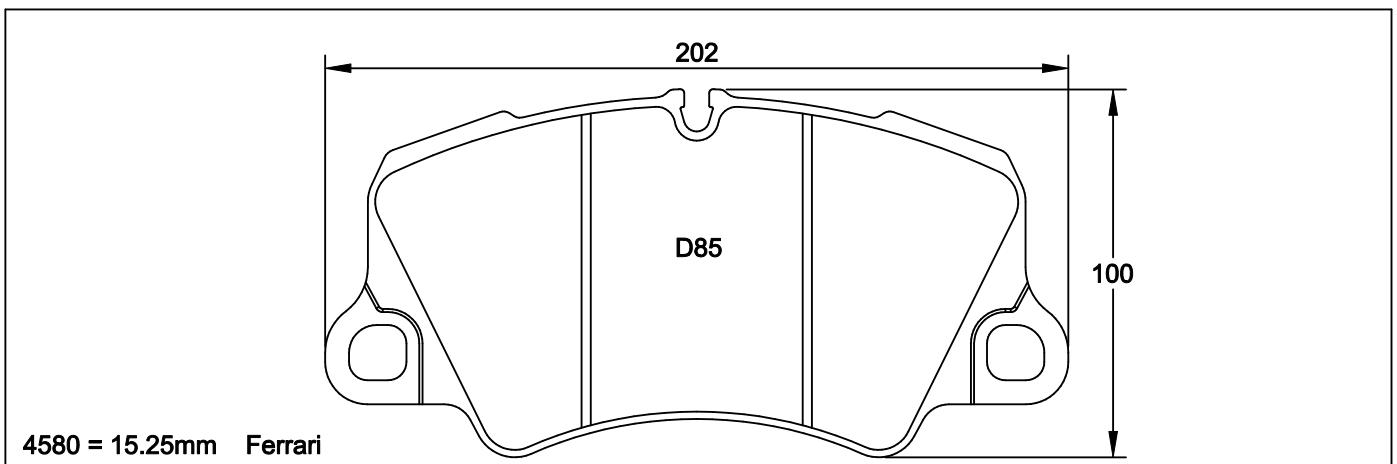
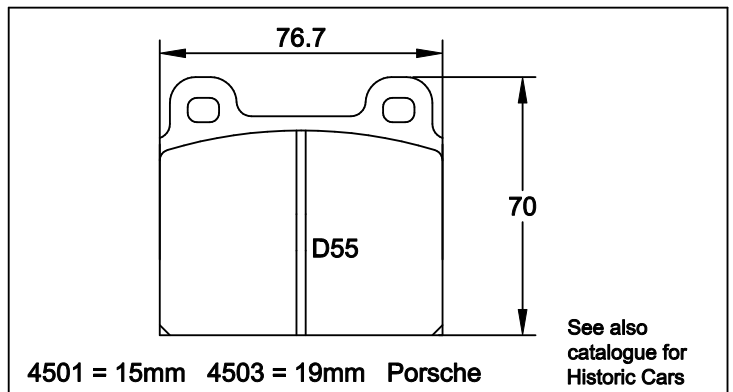
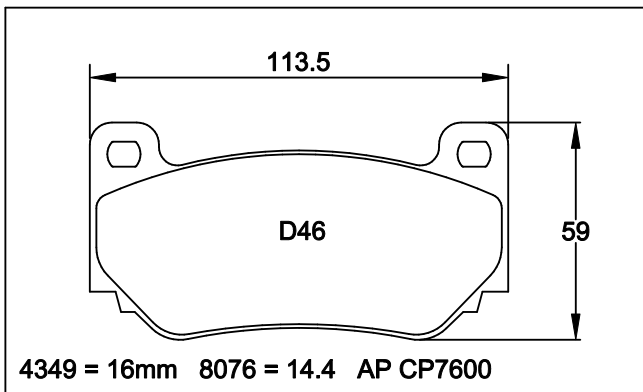
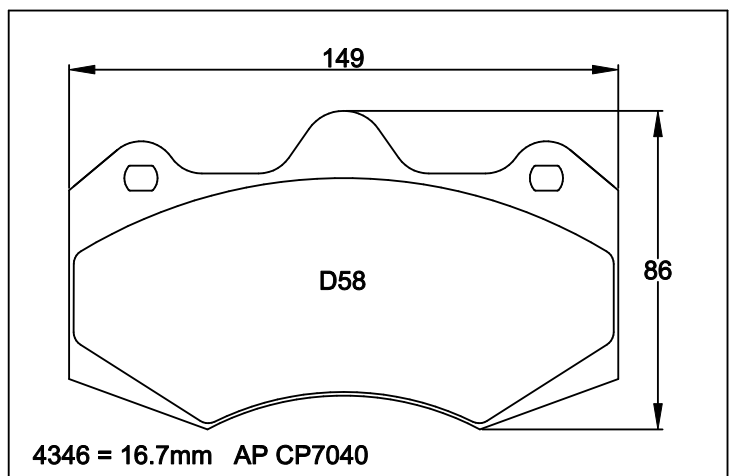
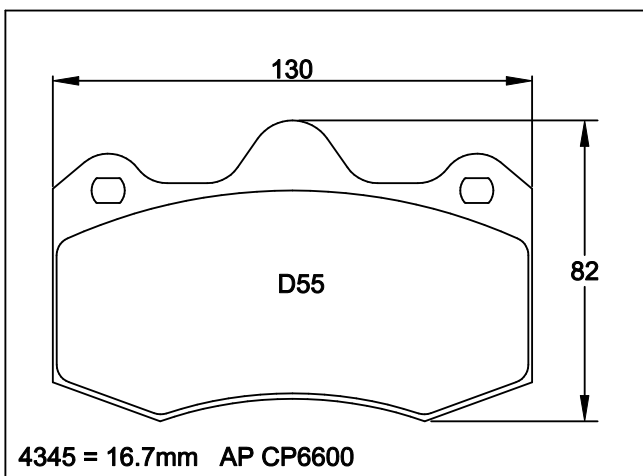
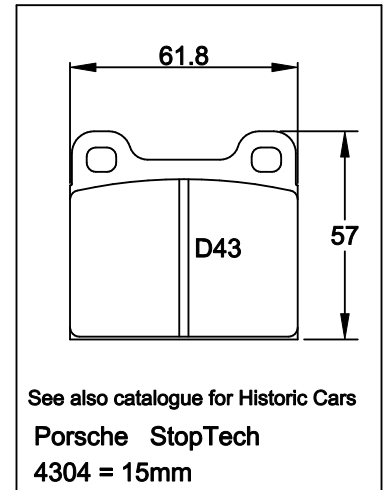
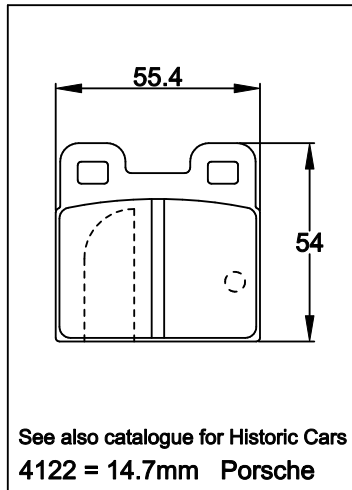
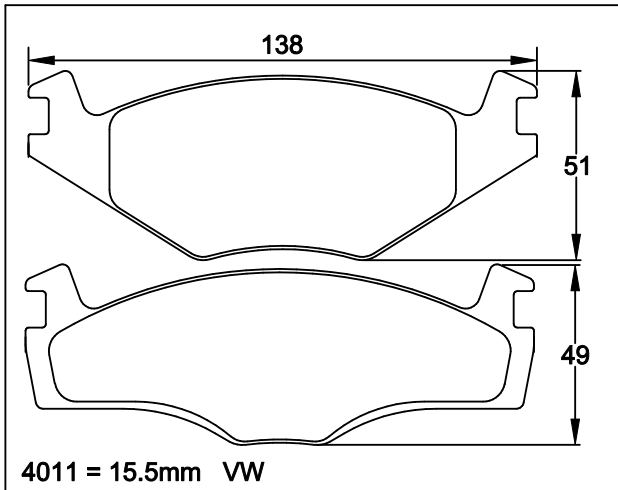

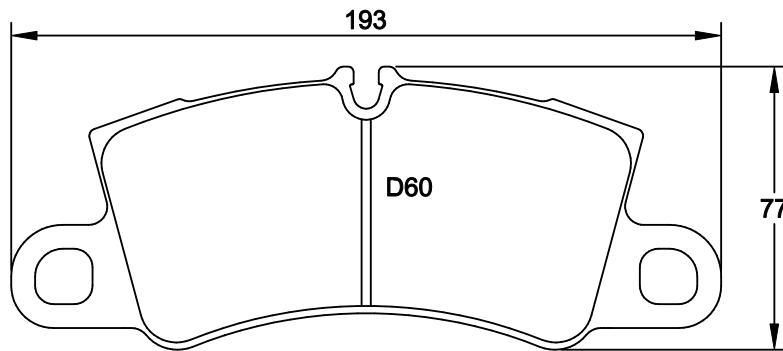

4581 = 15mm Ferrari

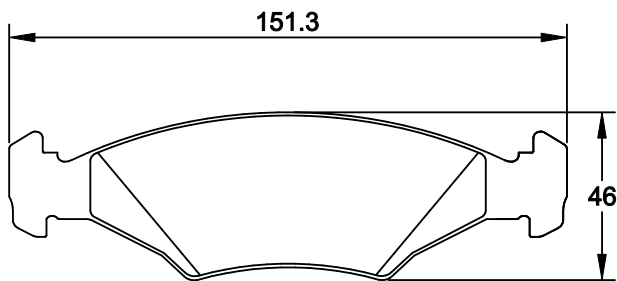

4823 = 18mm Ford

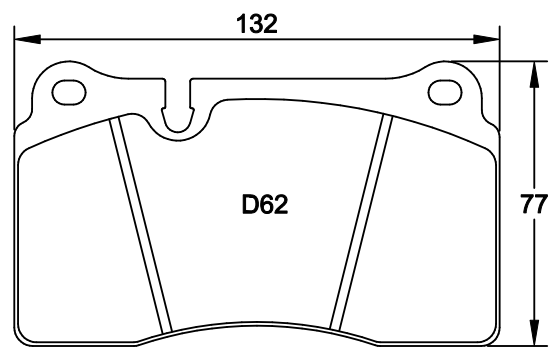

4906 = 16.3mm Ferrari rear (with wear sensor cut out)

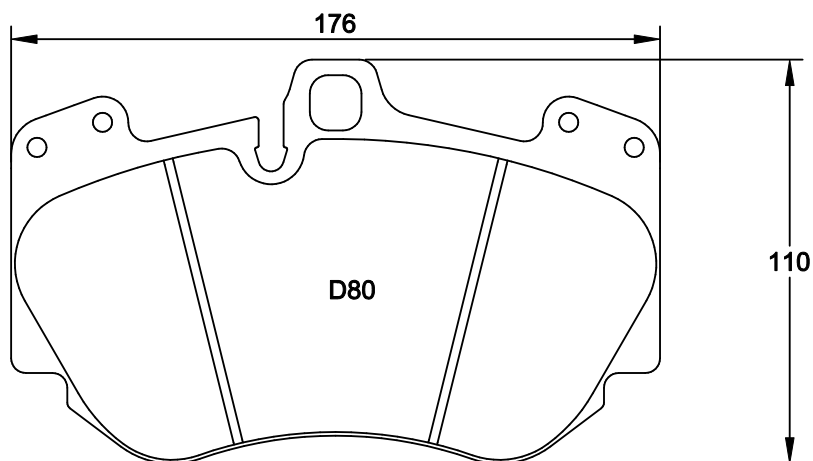

4907 = 16mm Audi

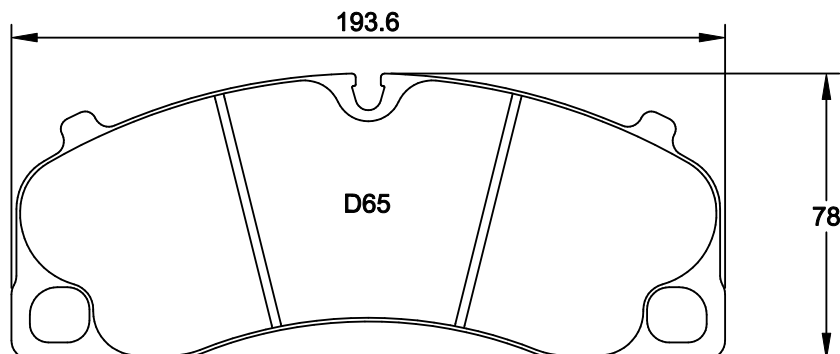

4908 = 15.6mm Porsche

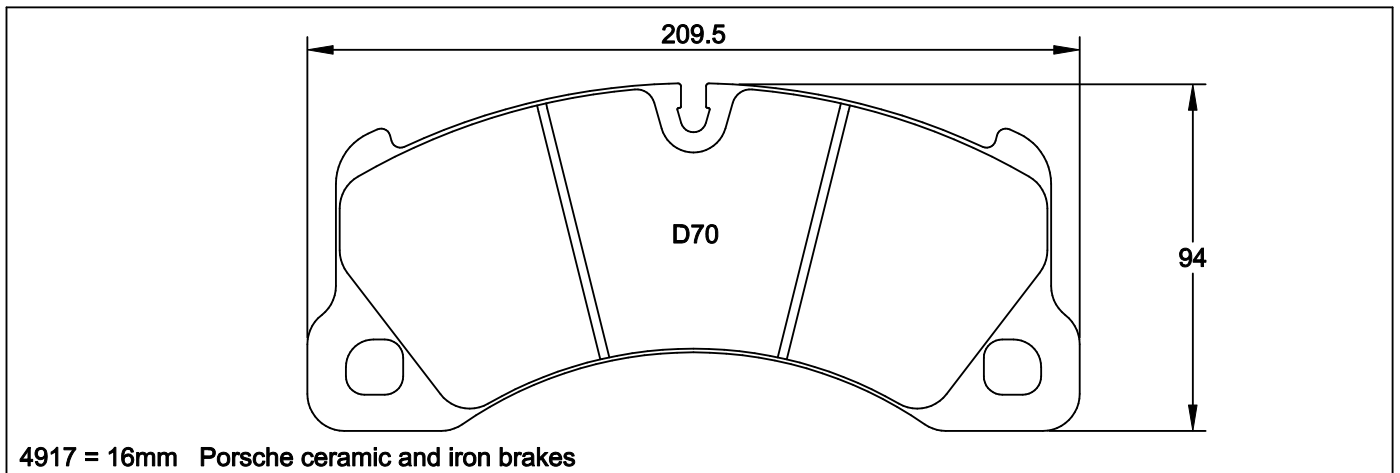
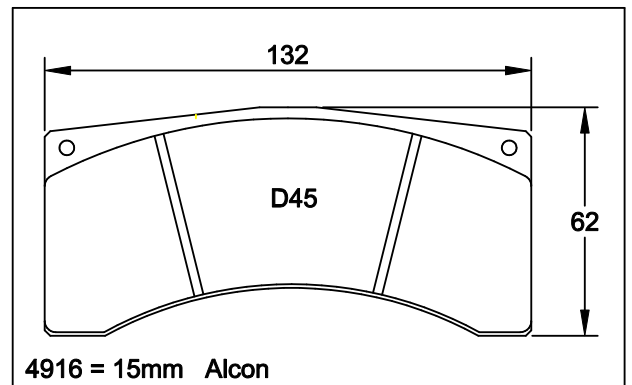
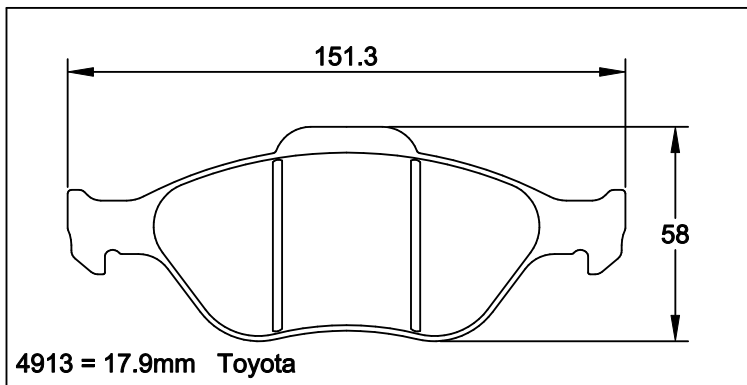
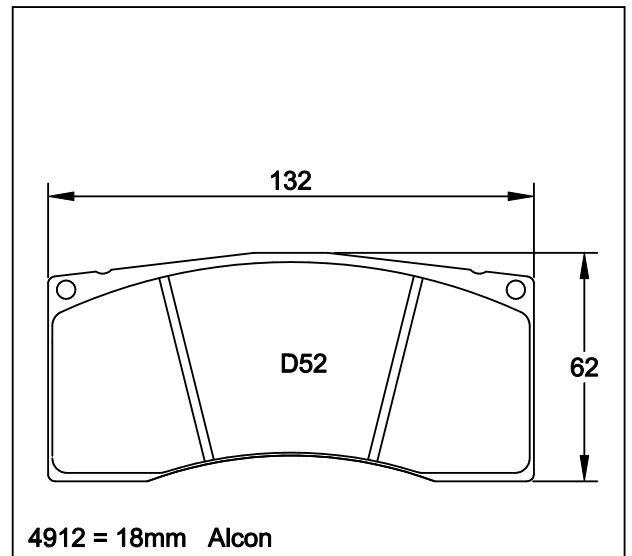
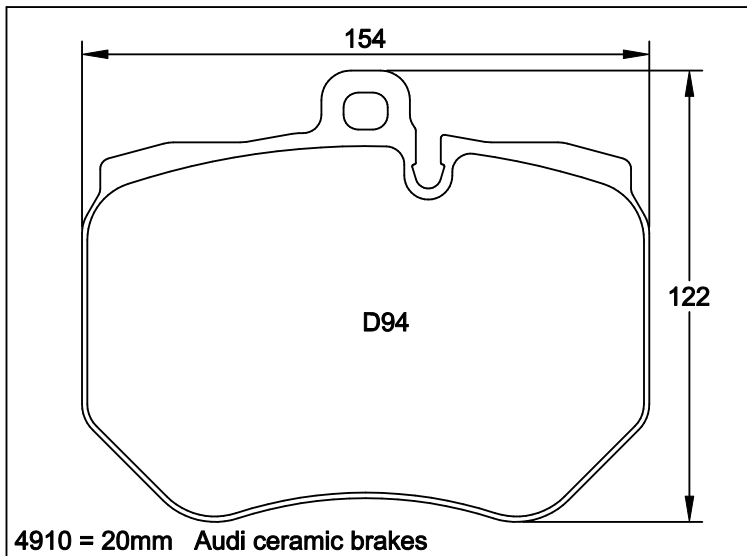
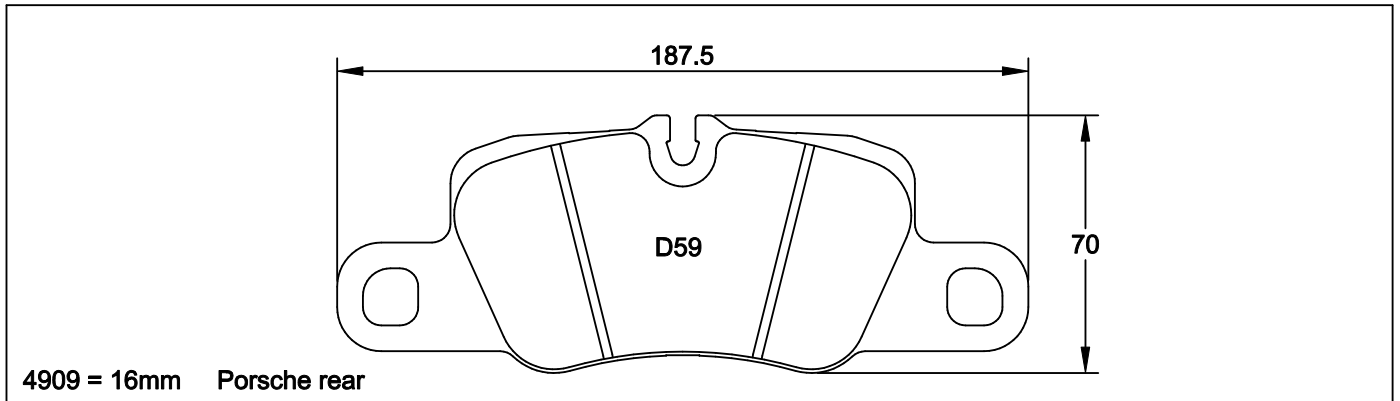

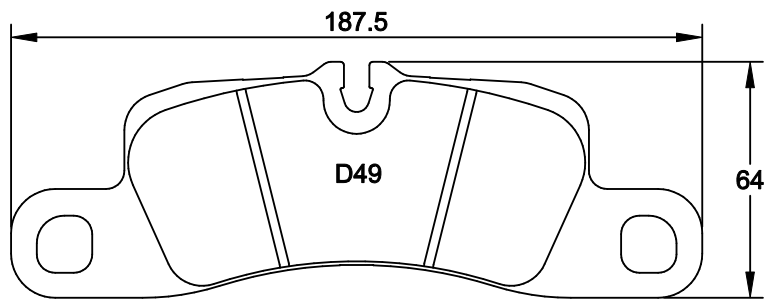

4918 = 16.3mm Porsche

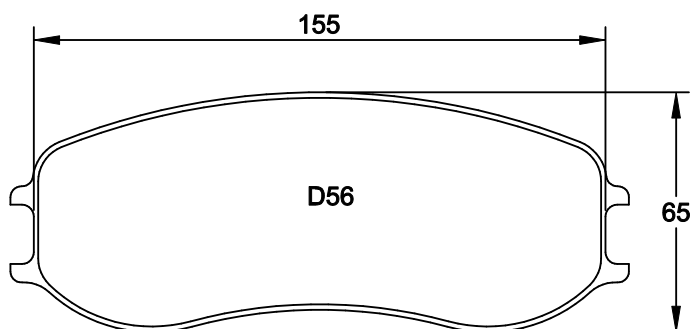

4920 = 22mm 4928 = 28mm
Porsche 991 GT3 Cup front

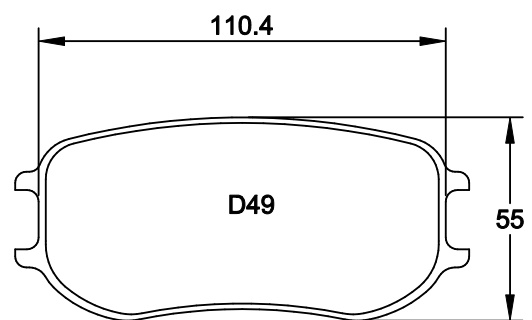

4921 = 20mm 4929 = 26mm
Porsche 991 GT3 Cup rear

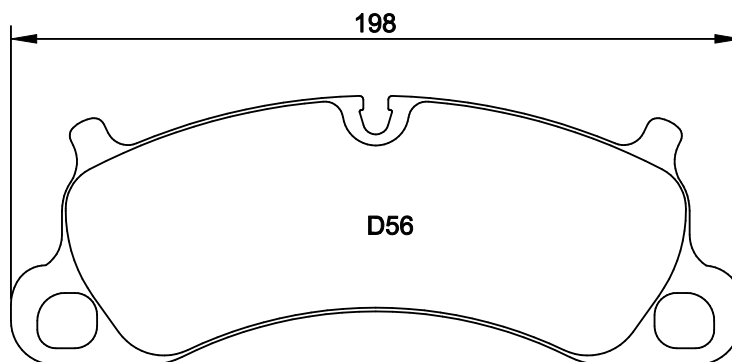

4922 = 17.3mm Porsche front

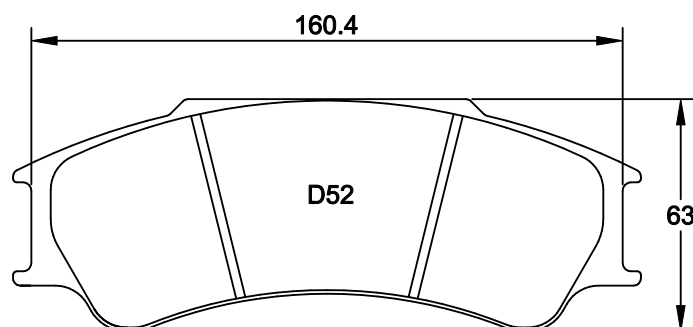

4923 = 29mm PFC 6 piston

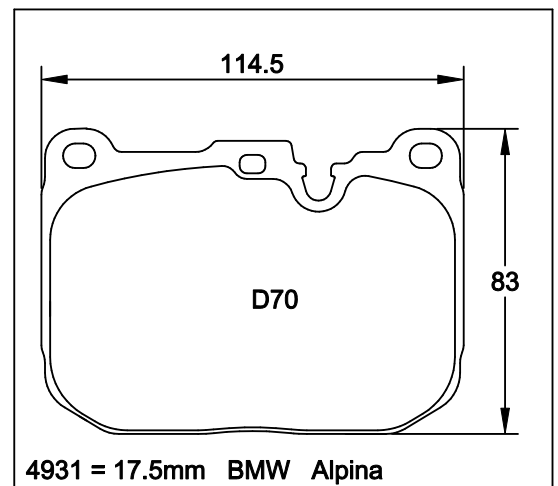
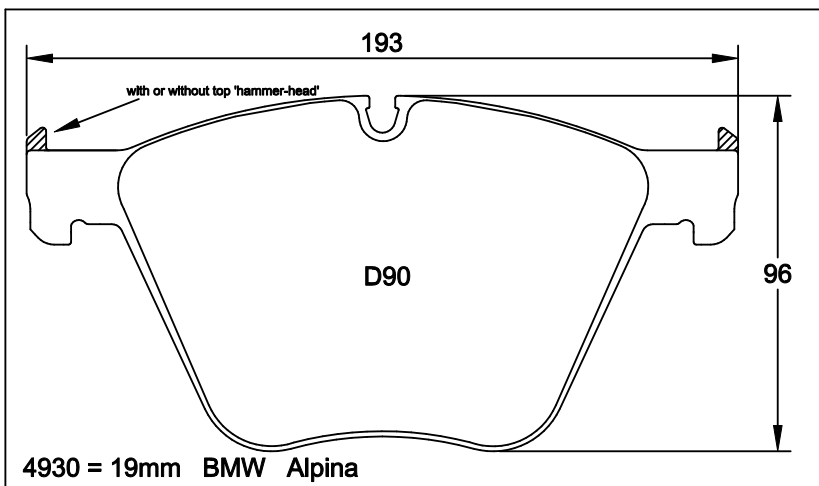
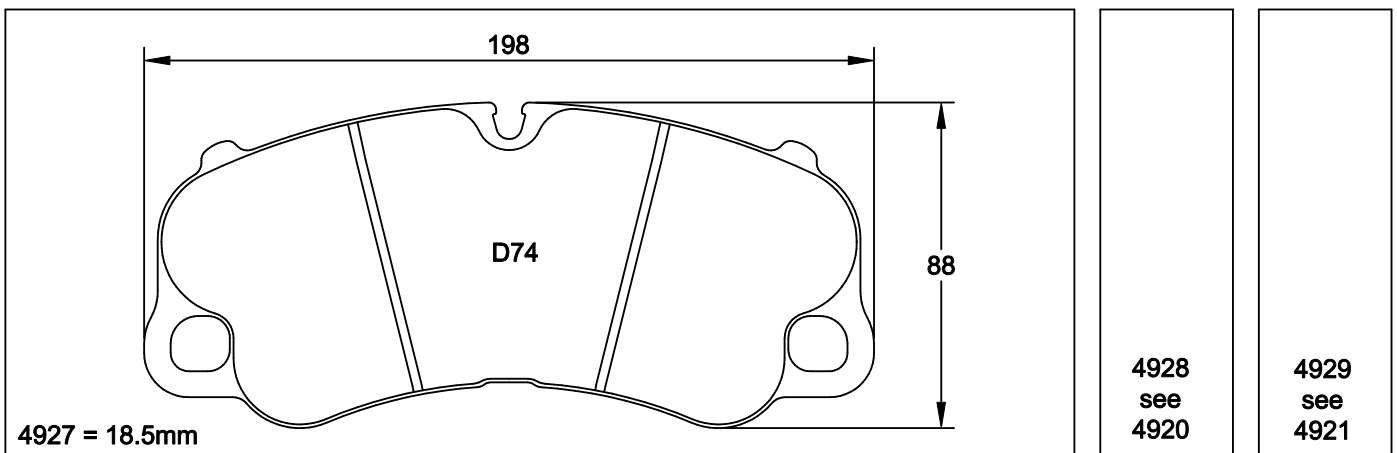
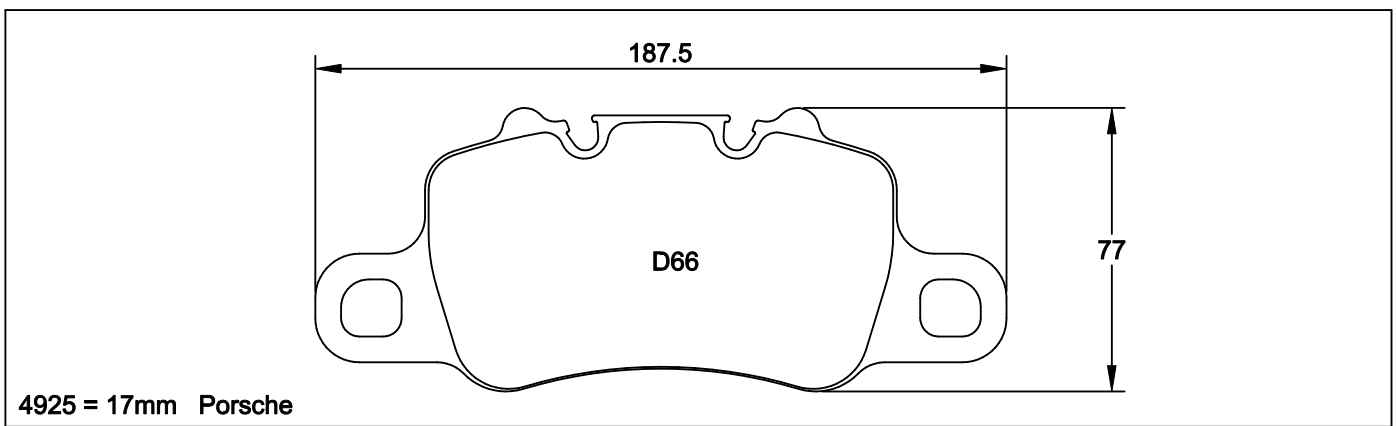
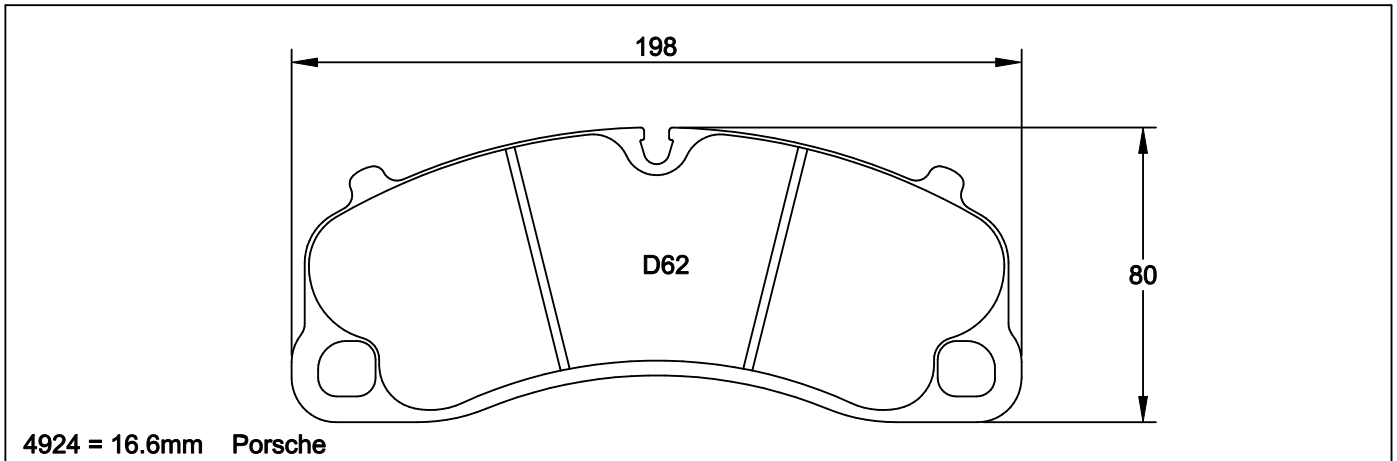

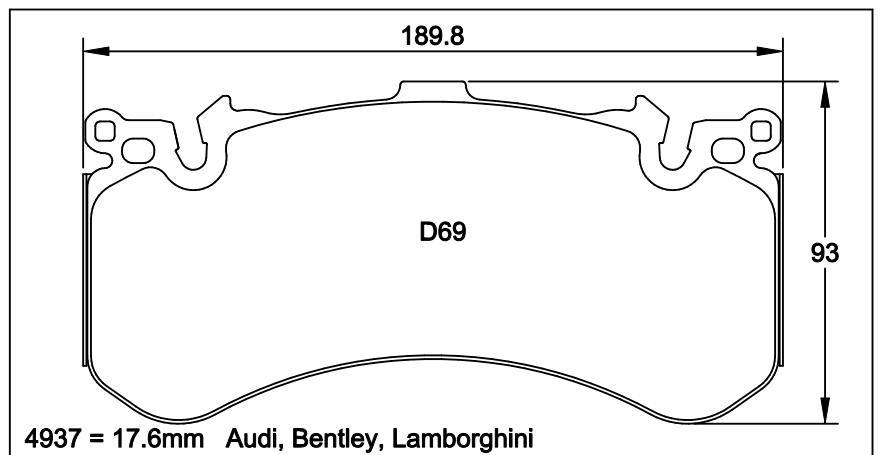
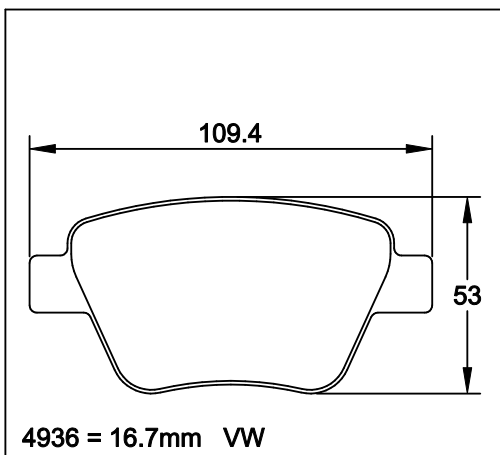
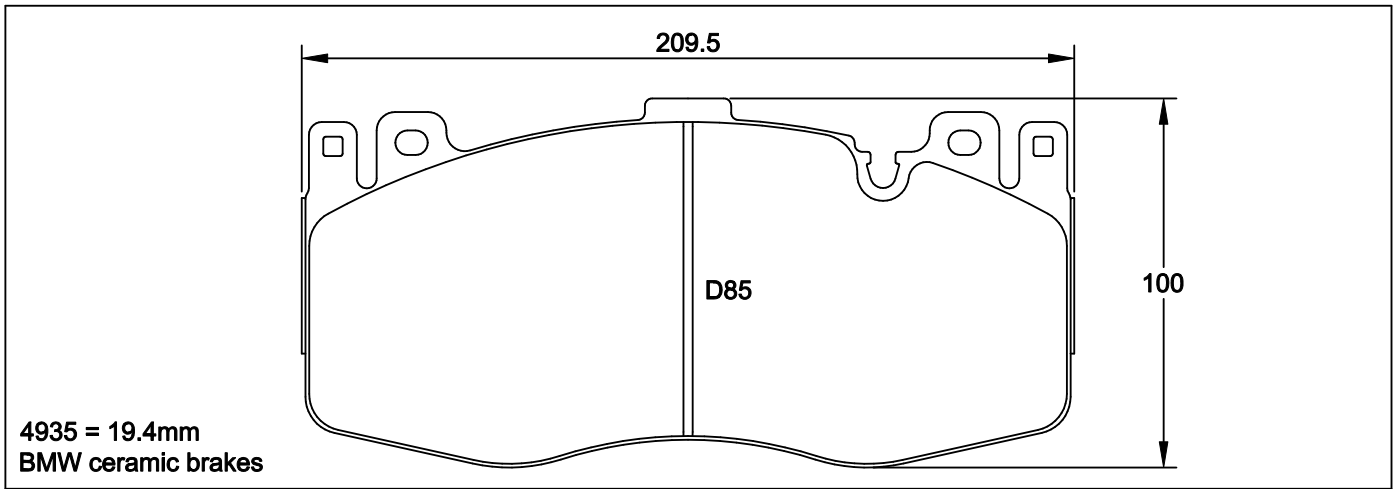
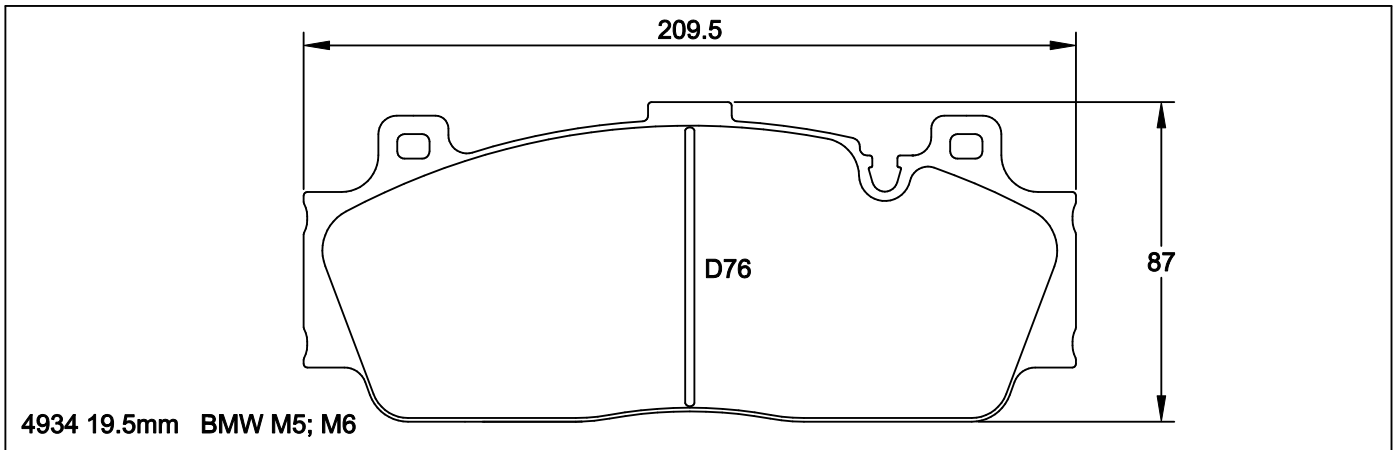
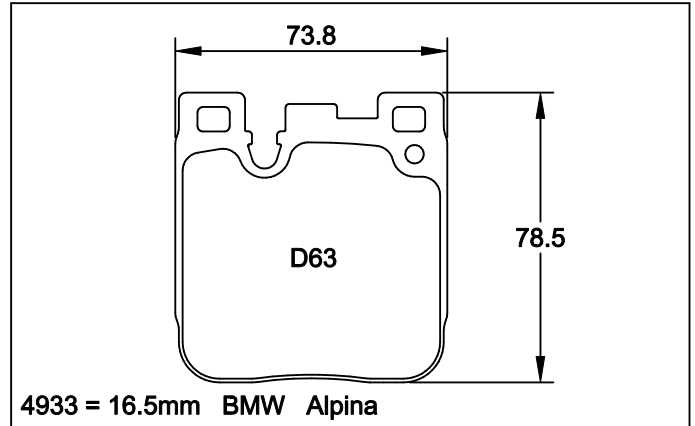
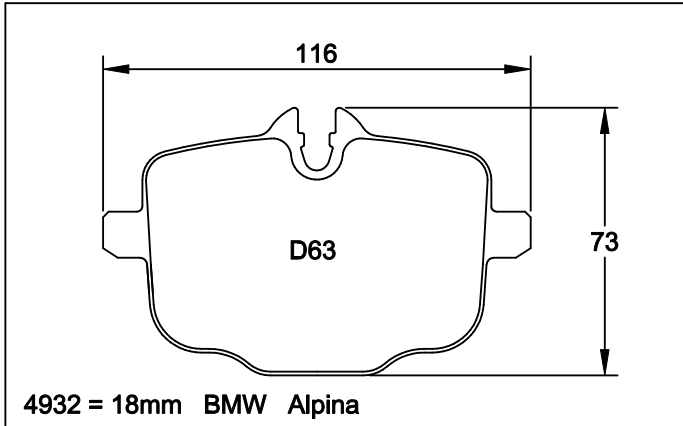

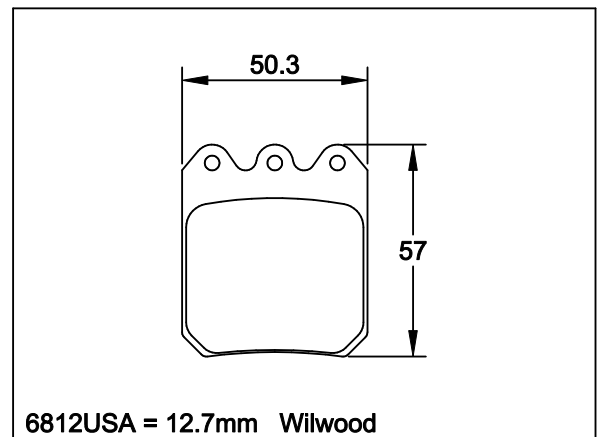
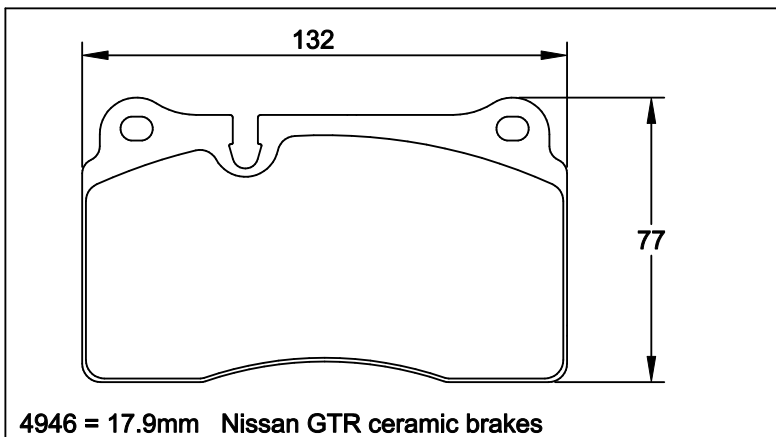
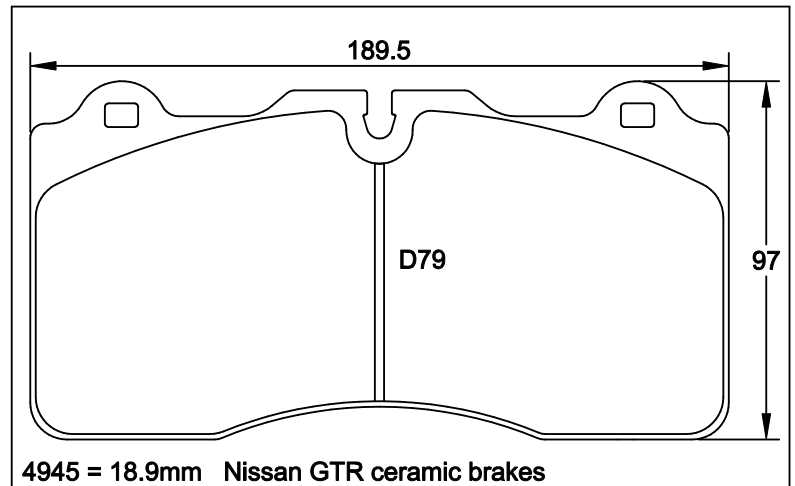
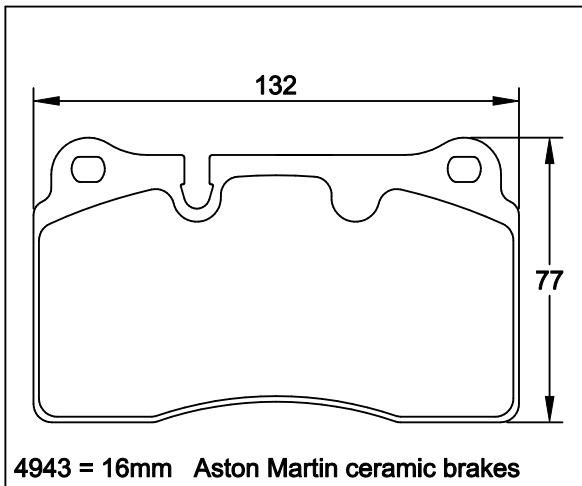
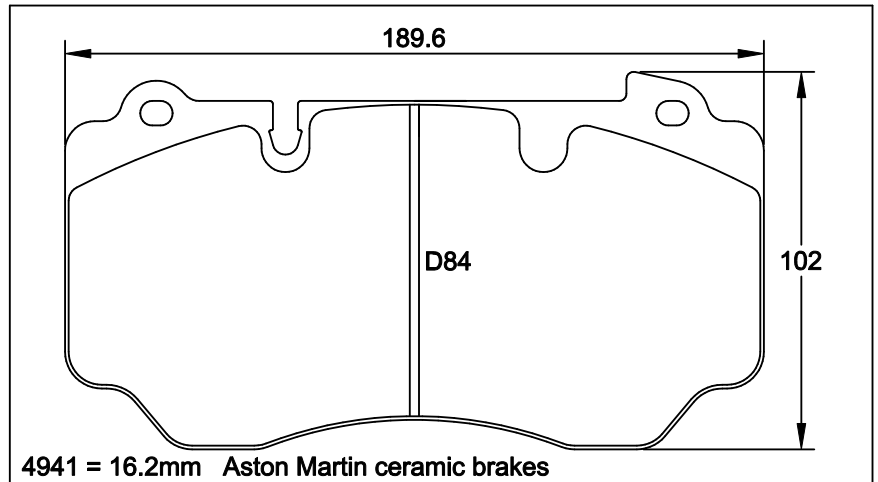
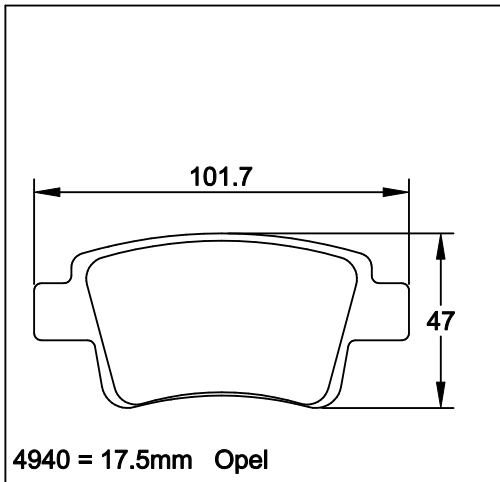
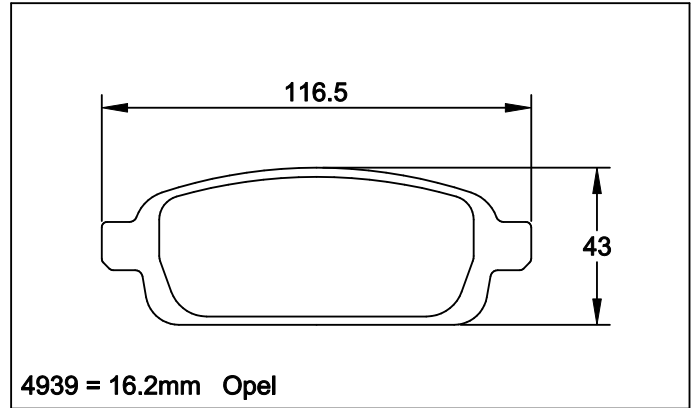
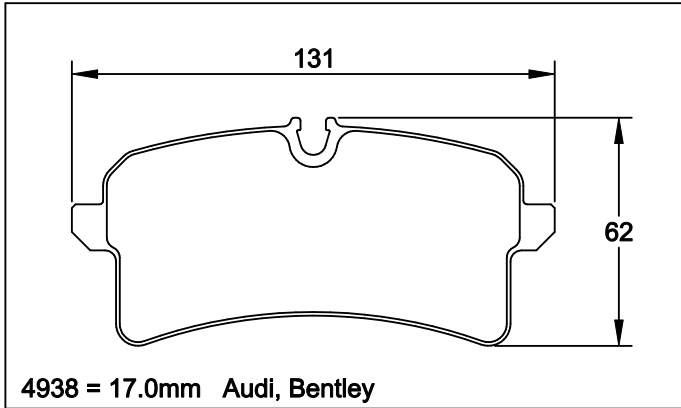

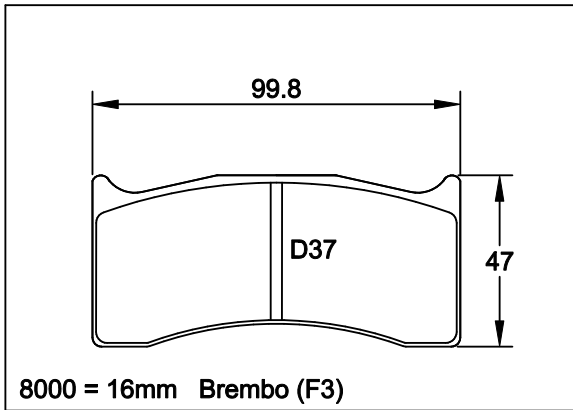

8000 = 16mm Brembo (F3)

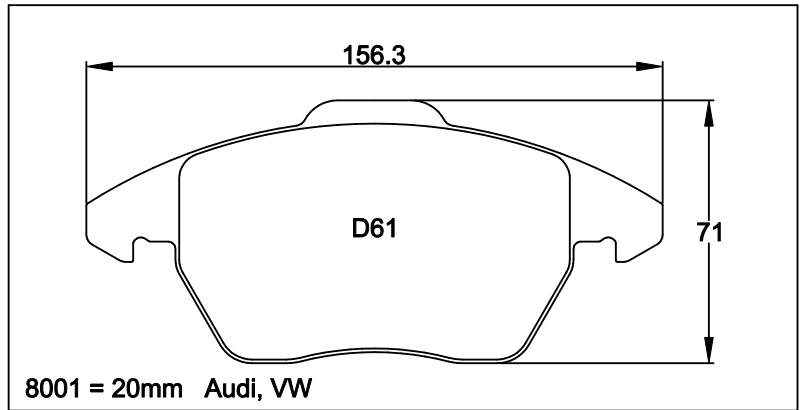

8001 = 20mm Audi, VW

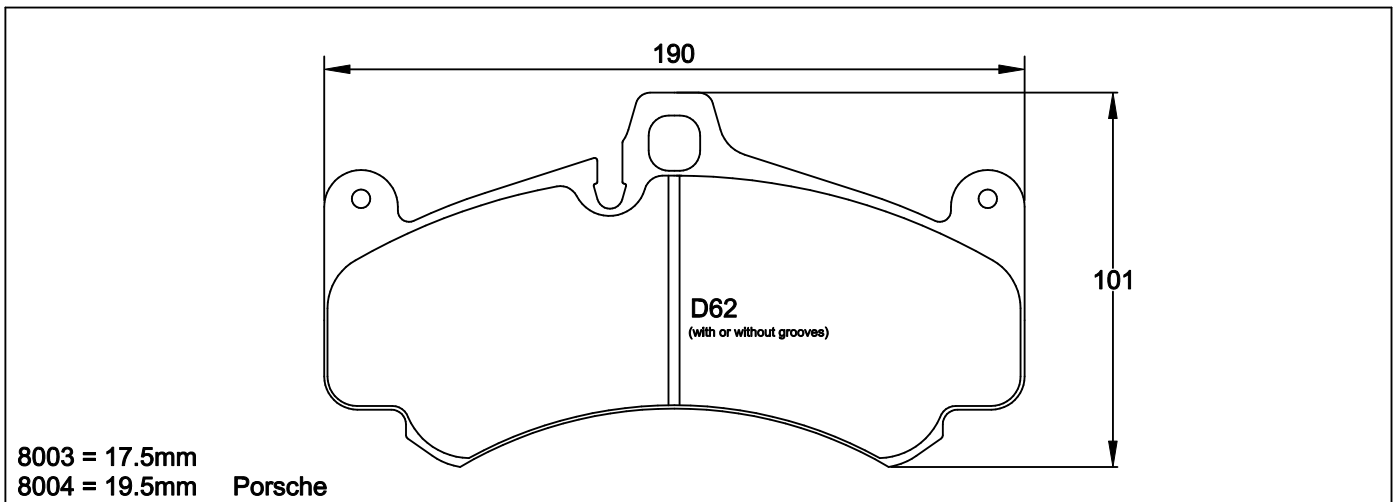

8003 = 17.5mm
8004 = 19.5mm Porsche

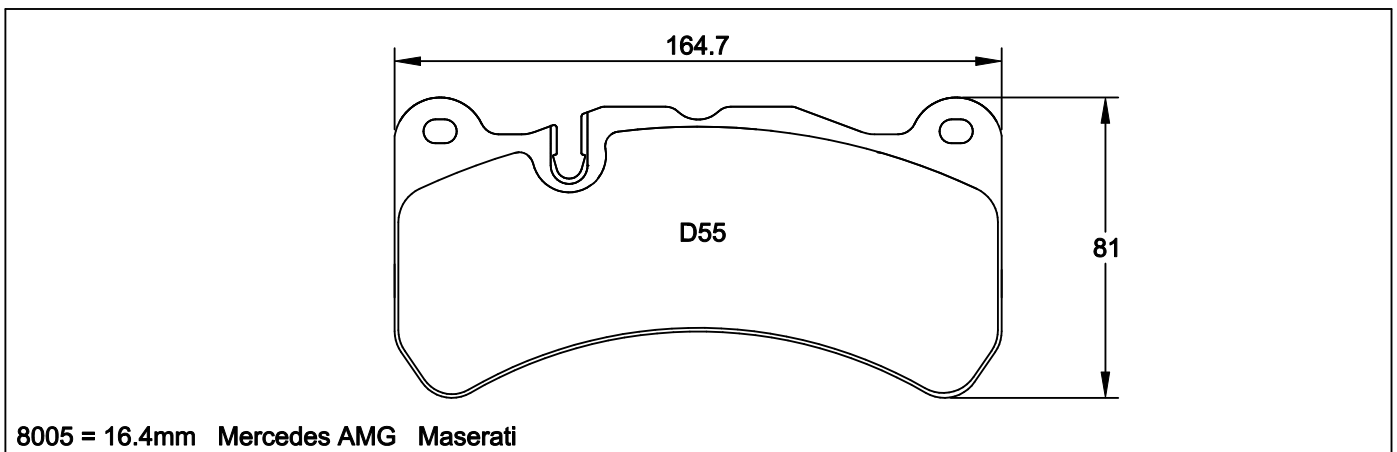

8005 = 16.4mm Mercedes AMG Maserati

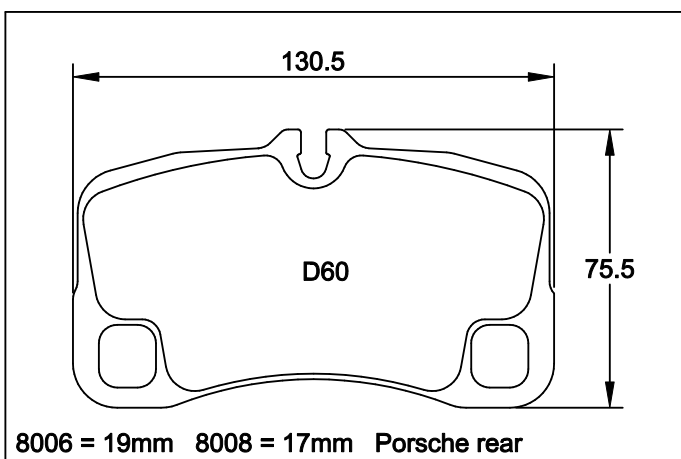

8006 = 19mm 8008 = 17mm Porsche rear

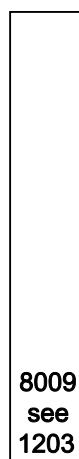

8009
see
1203

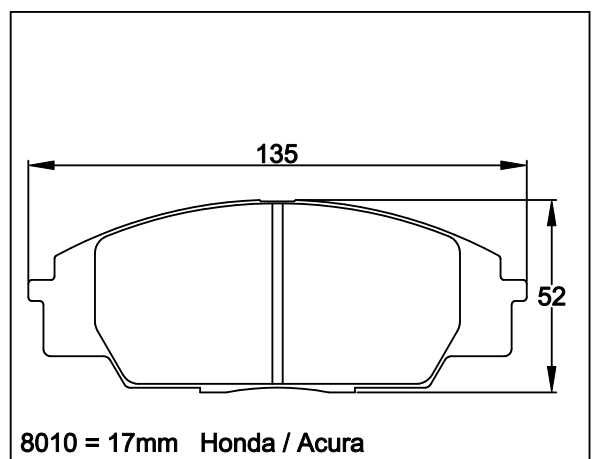

8010 = 17mm Honda / Acura

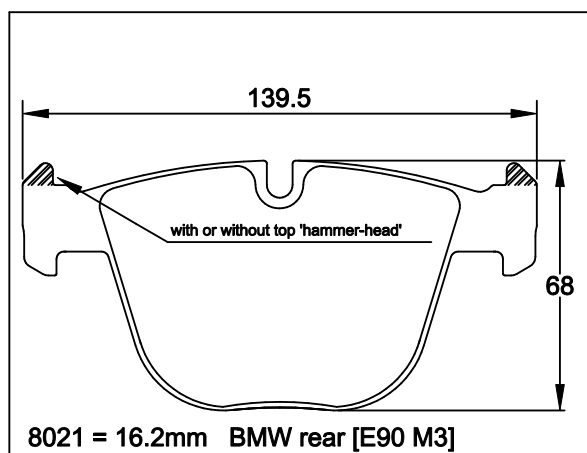
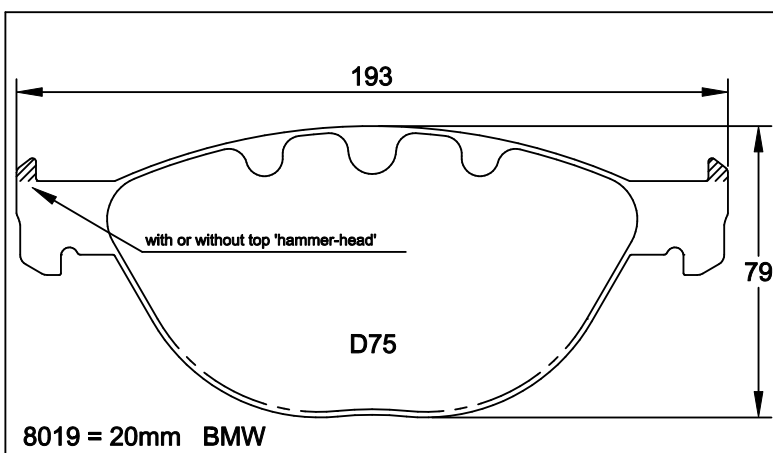
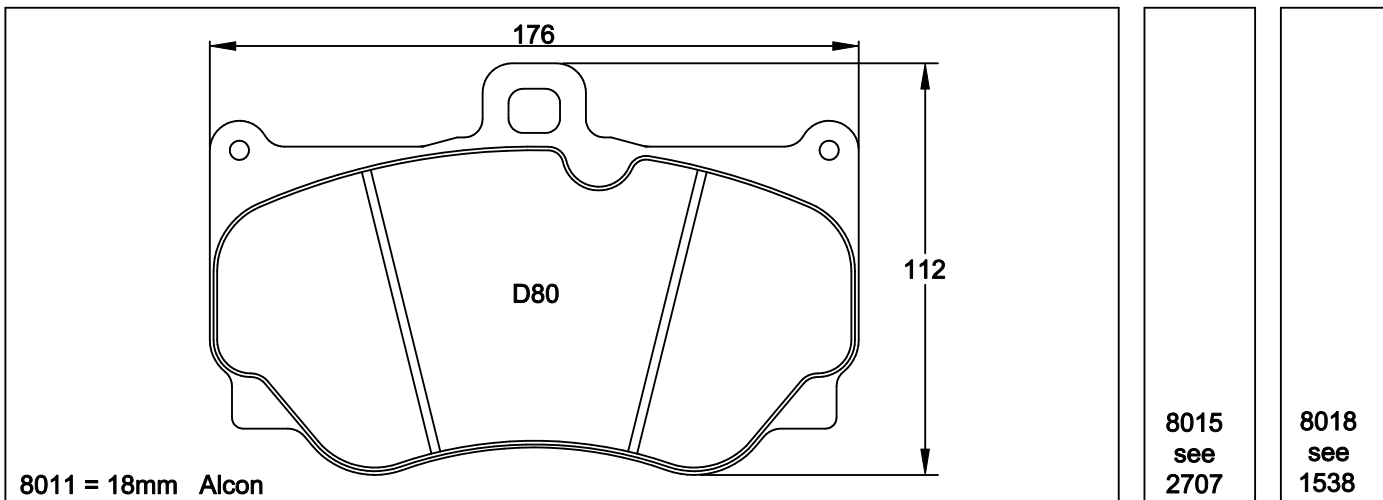

45

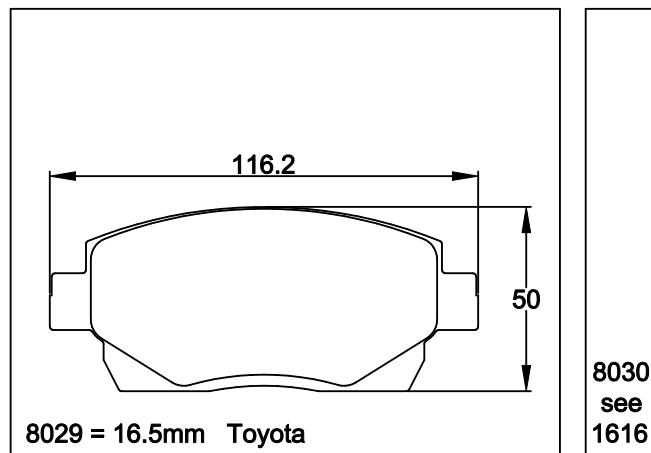
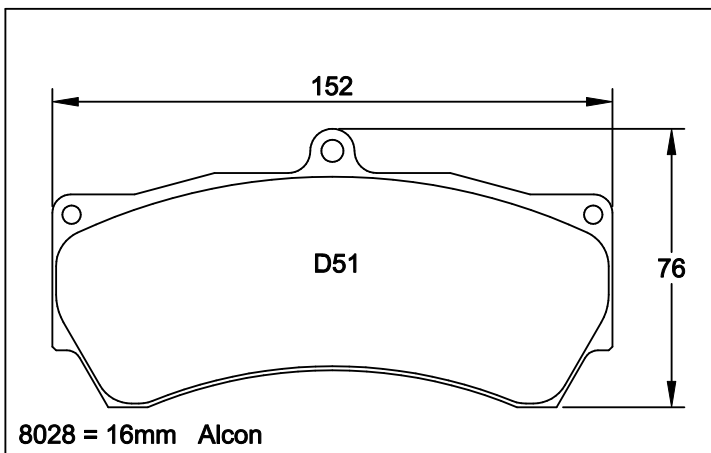
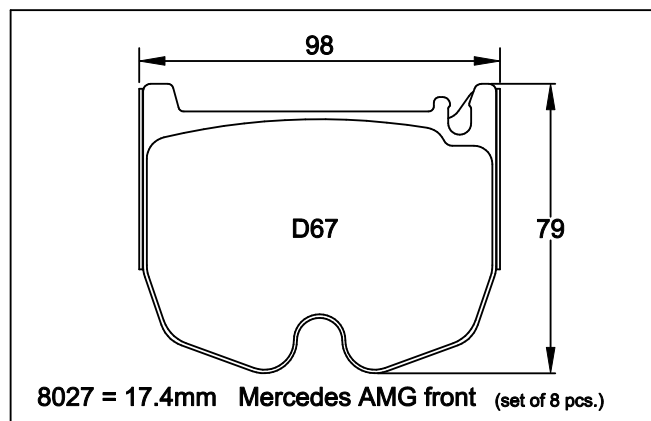
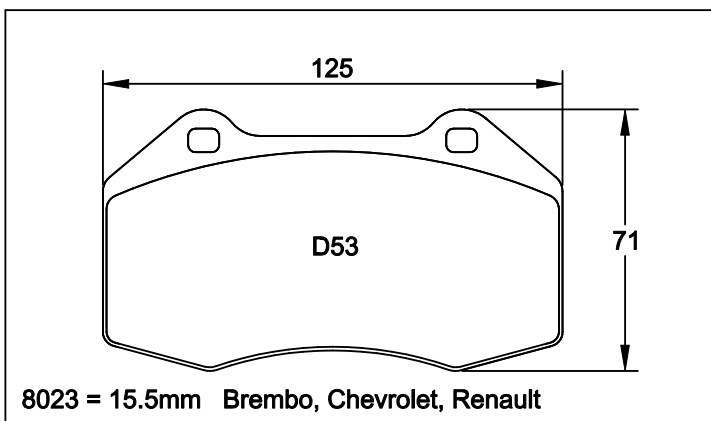

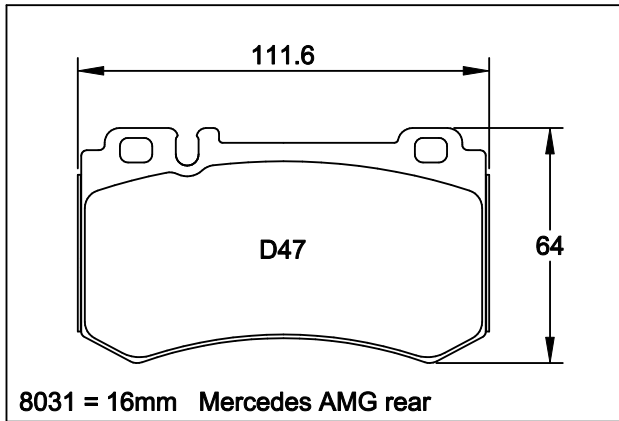

8033
see
3277

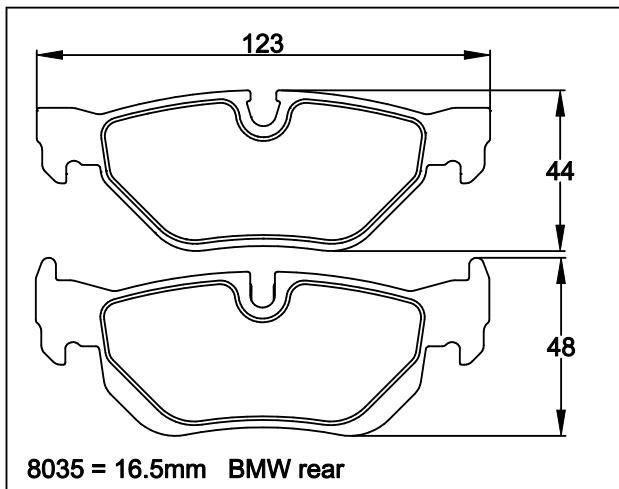
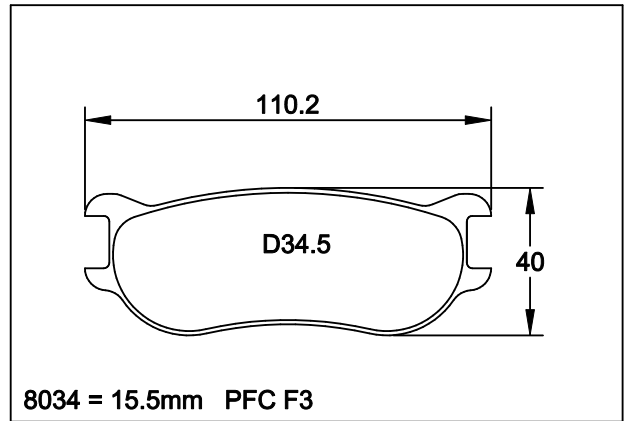

8037
see
1595

8038
see
2488

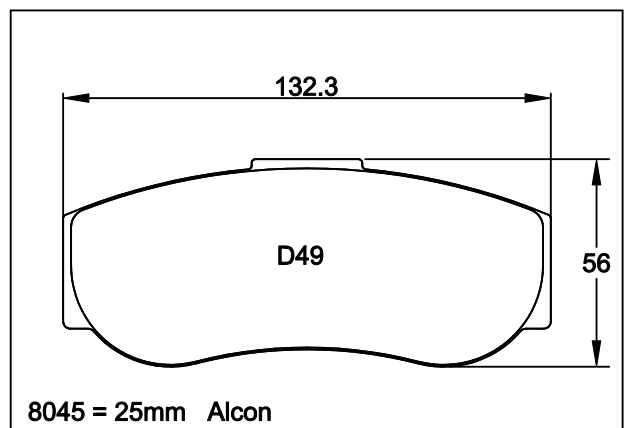
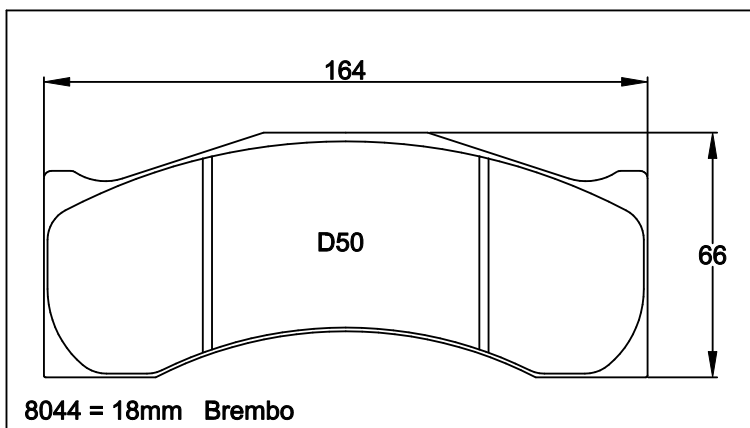
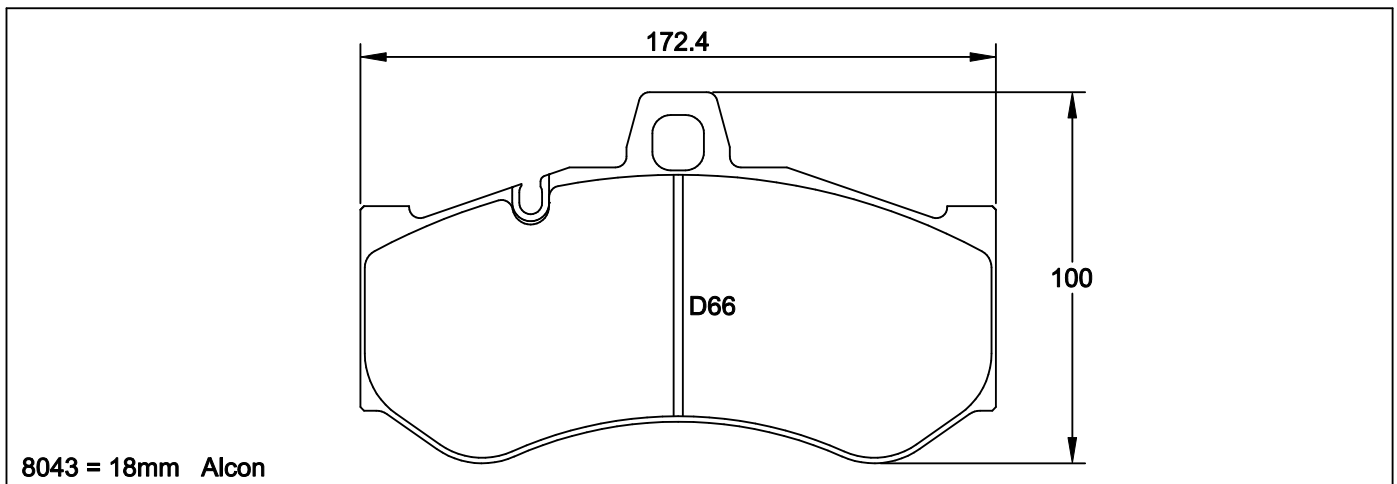
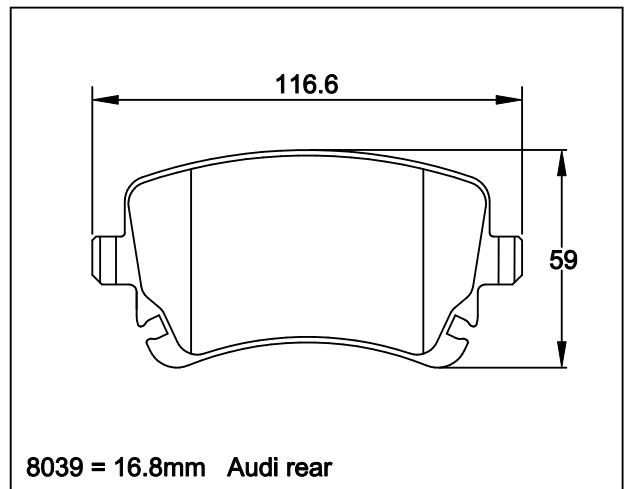

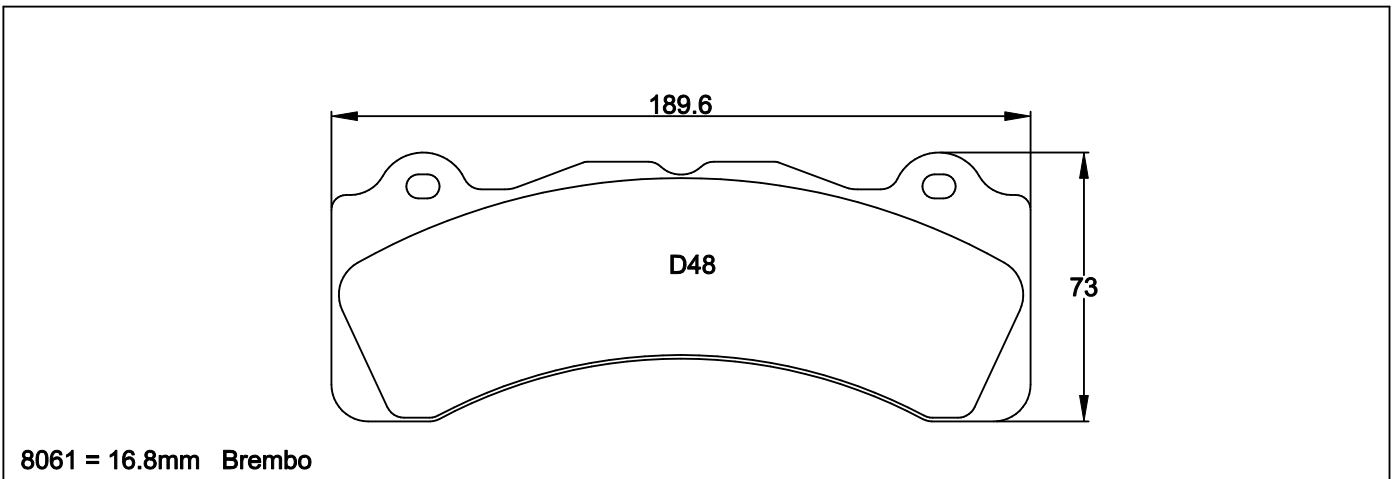
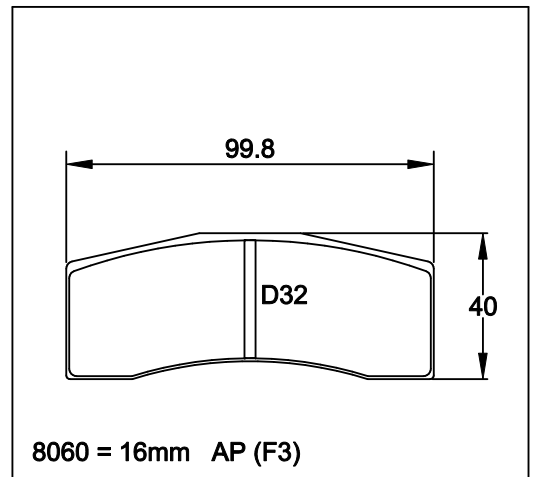
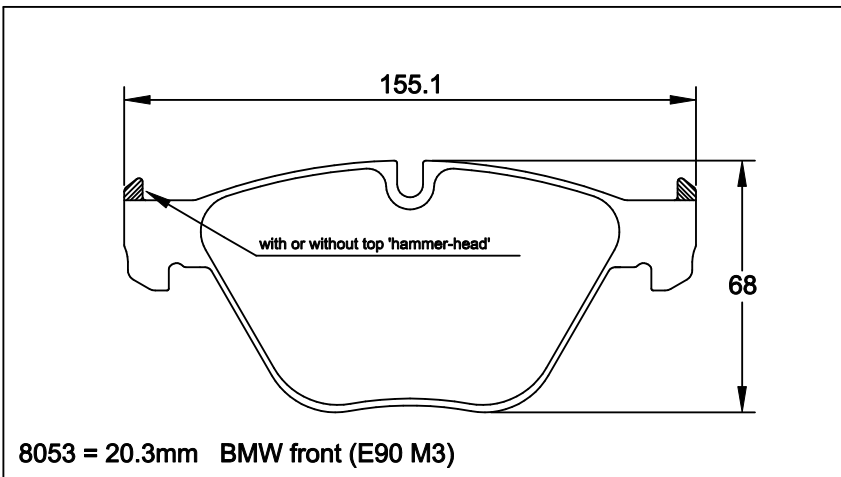
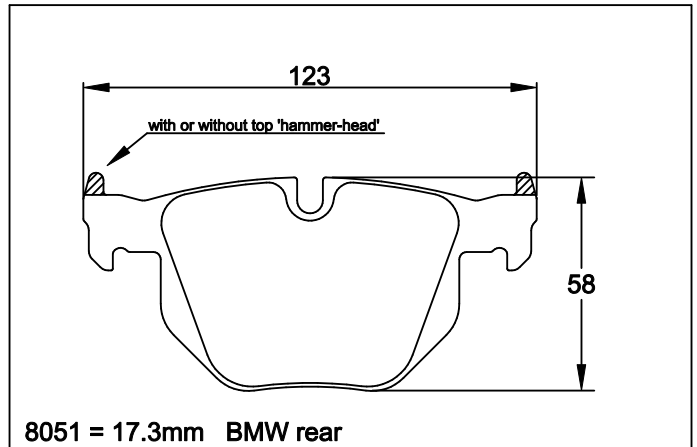
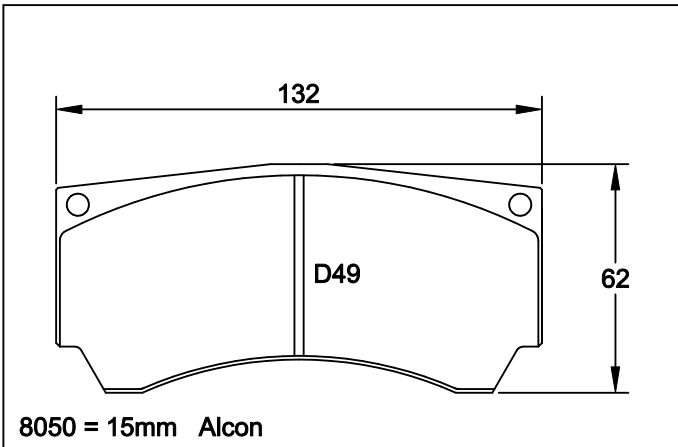
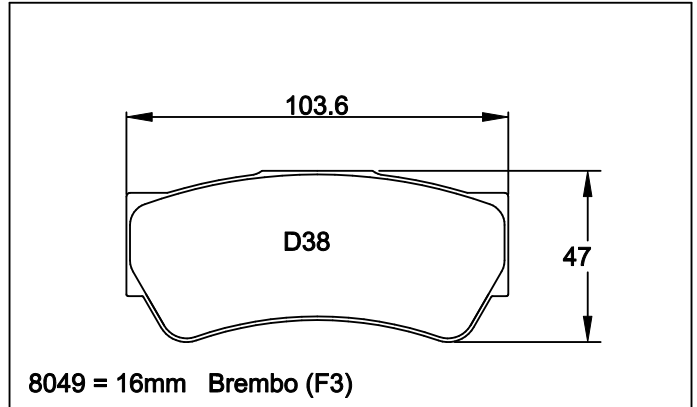
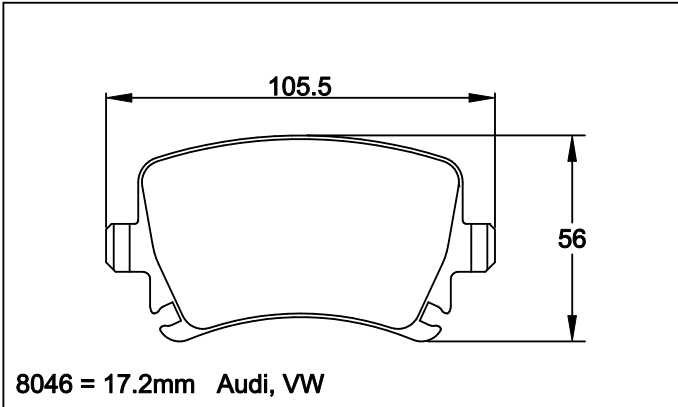

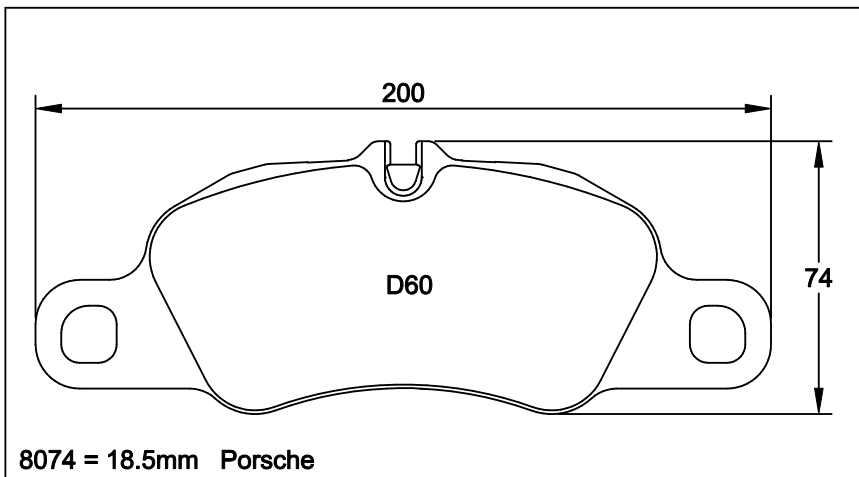
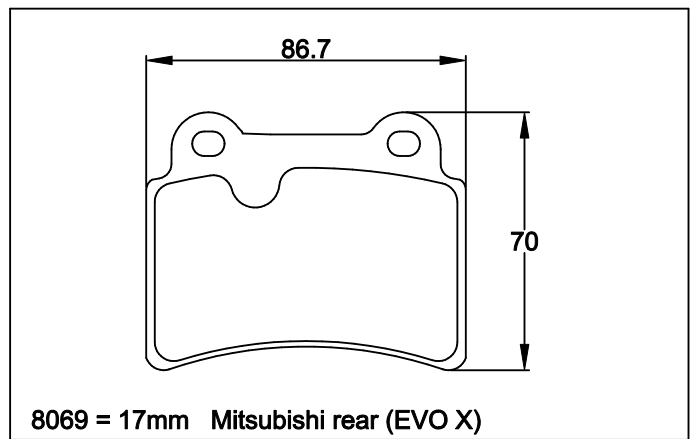
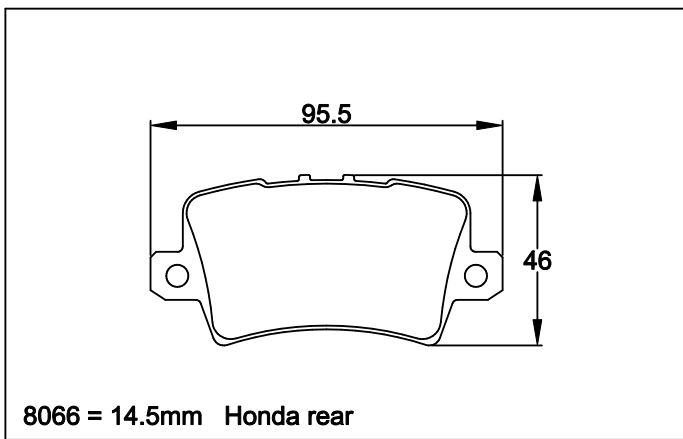
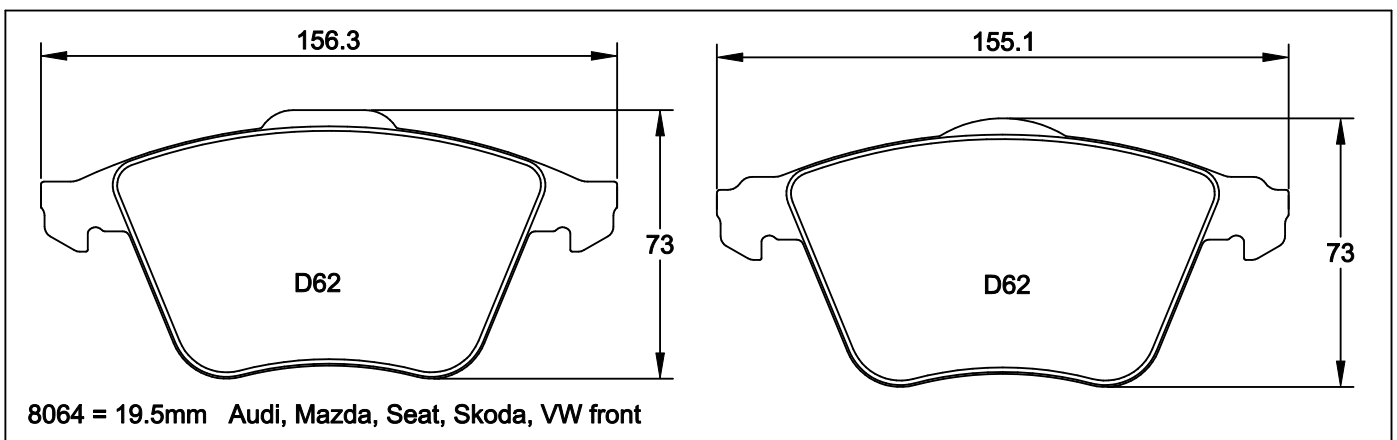
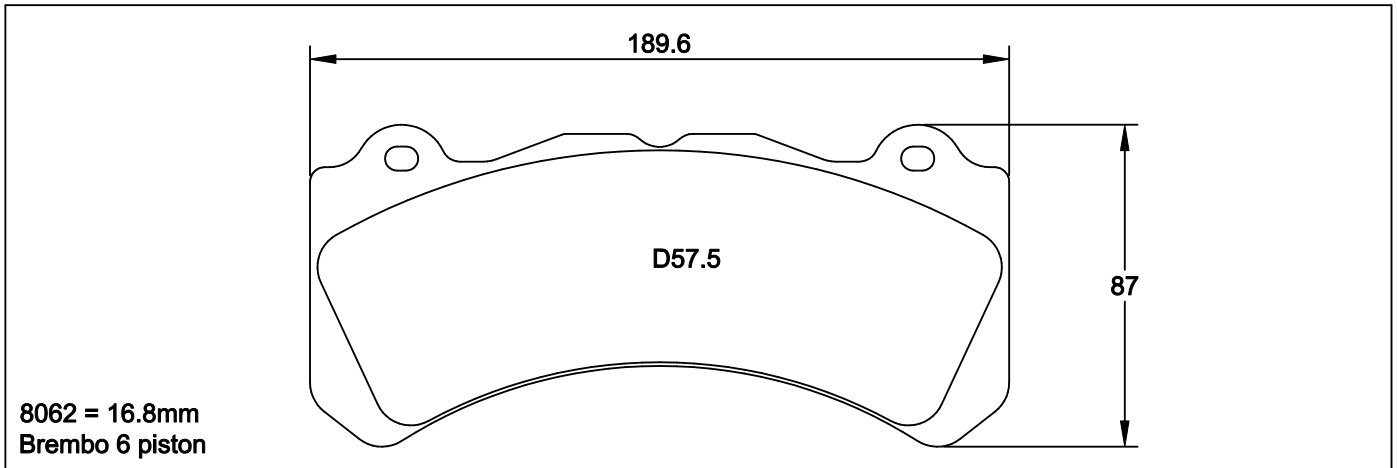

8076 see 4349

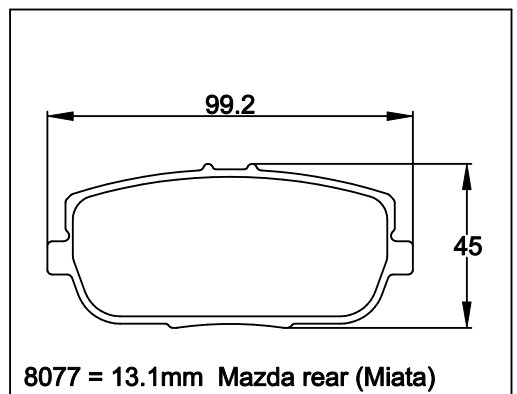

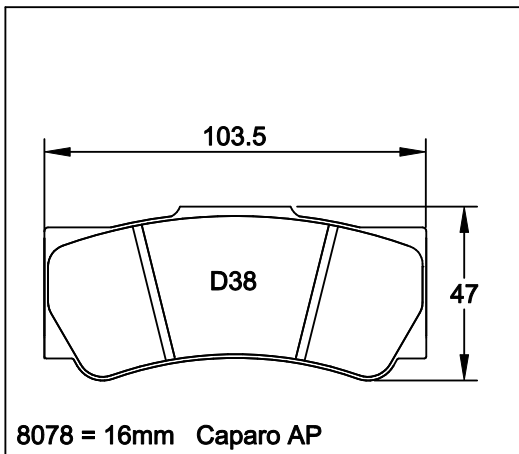

8078 = 16mm Caparo AP

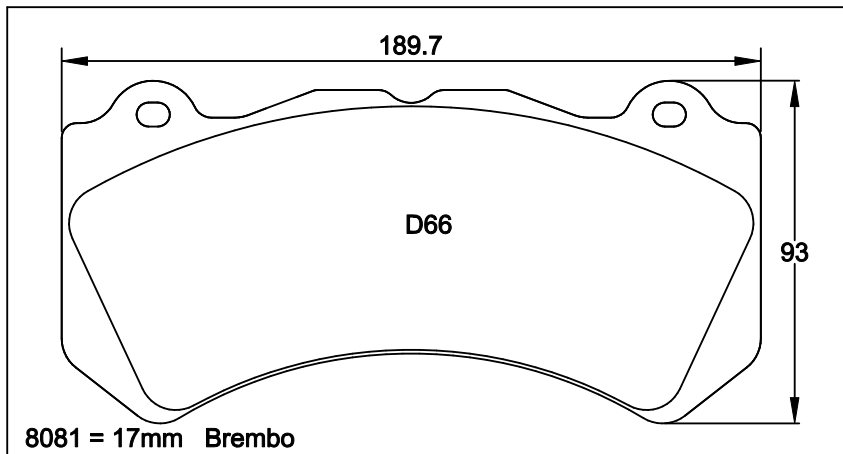

8081 = 17mm Brembo

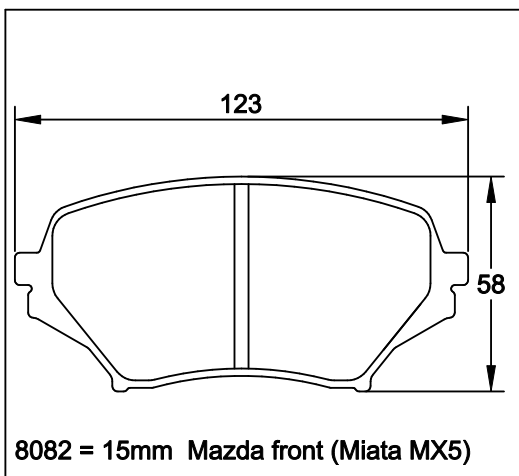

8082 = 15mm Mazda front (Miata MX5)

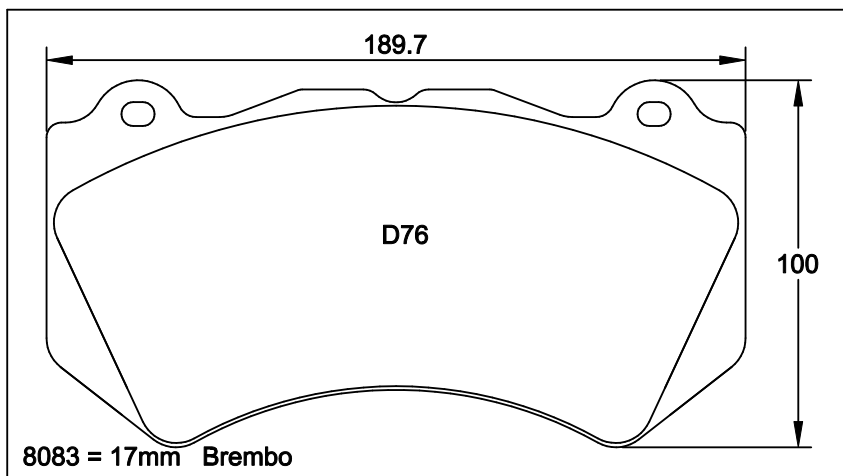

8083 = 17mm Brembo

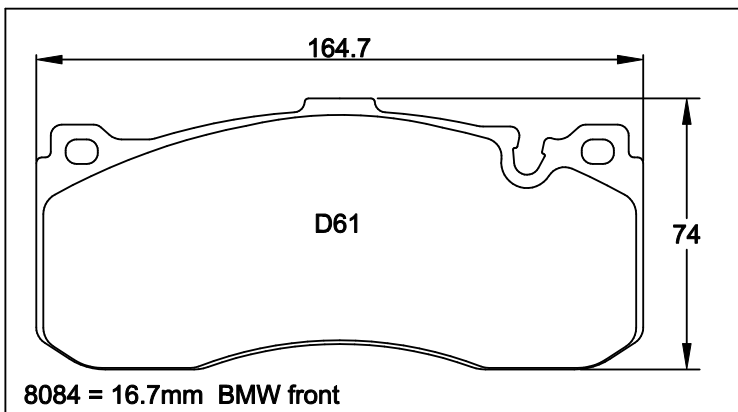

8084 = 16.7mm BMW front

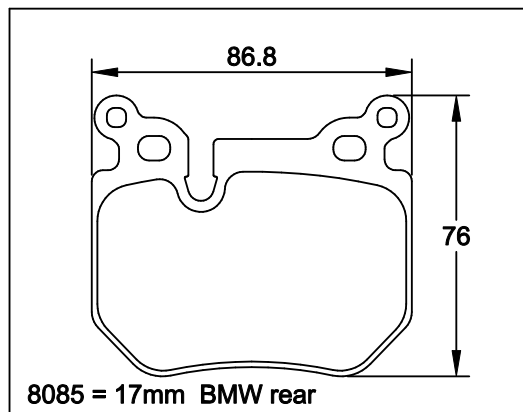

8085 = 17mm BMW rear

8087
see
2488

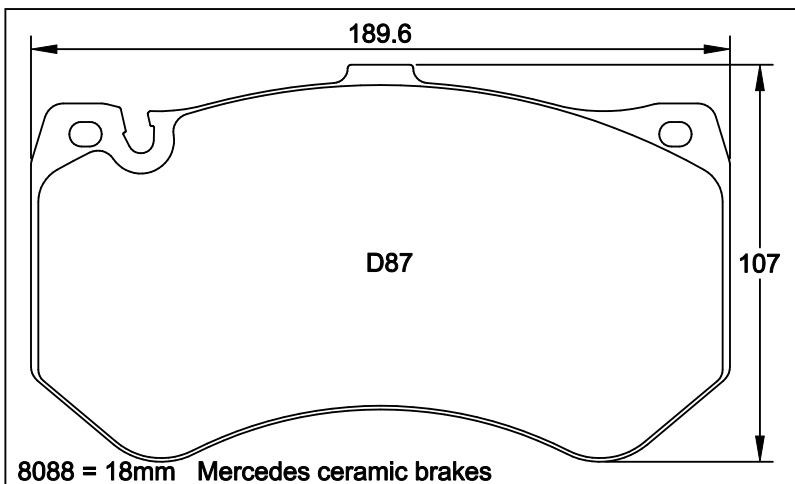

8088 = 18mm Mercedes ceramic brakes

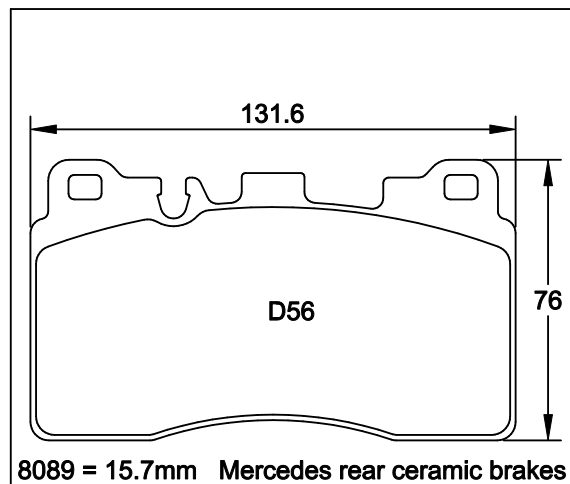

8089 = 15.7mm Mercedes rear ceramic brakes

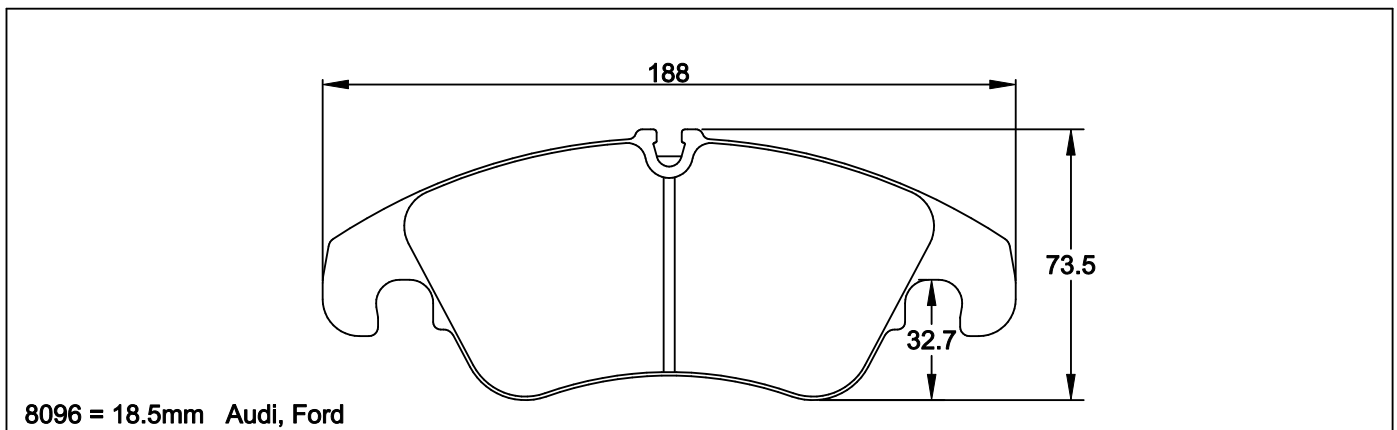
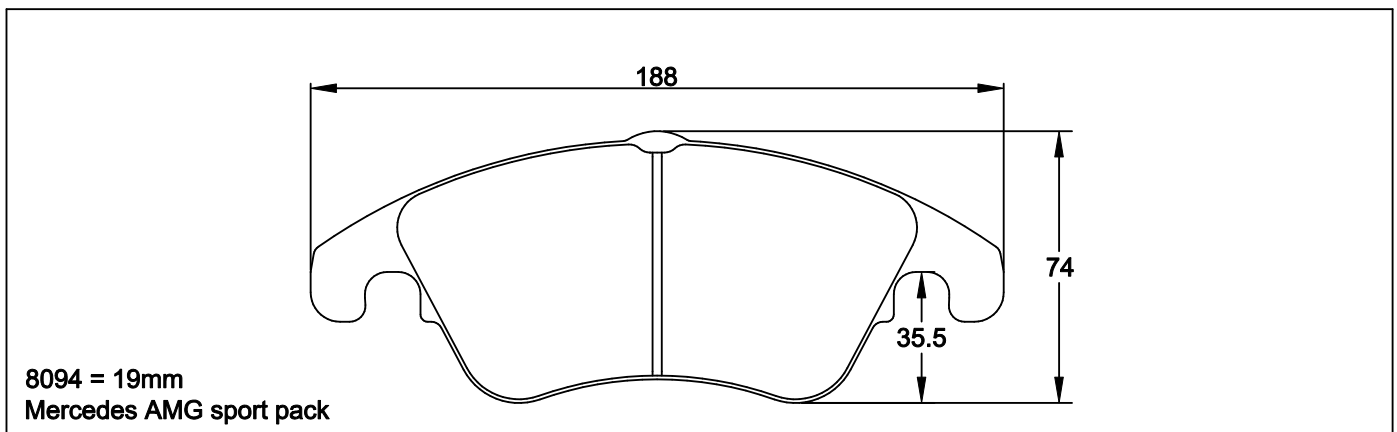
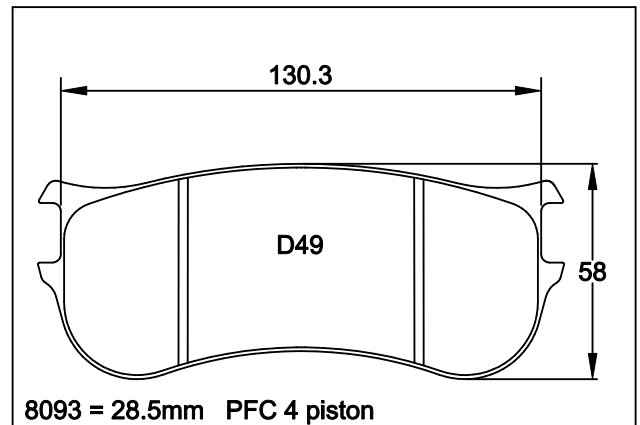
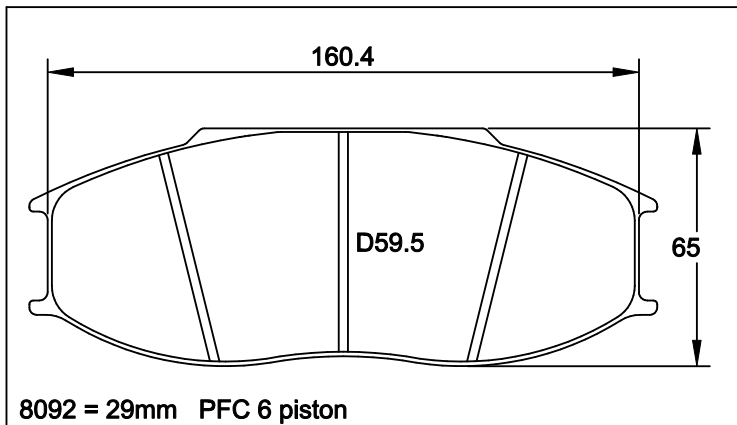
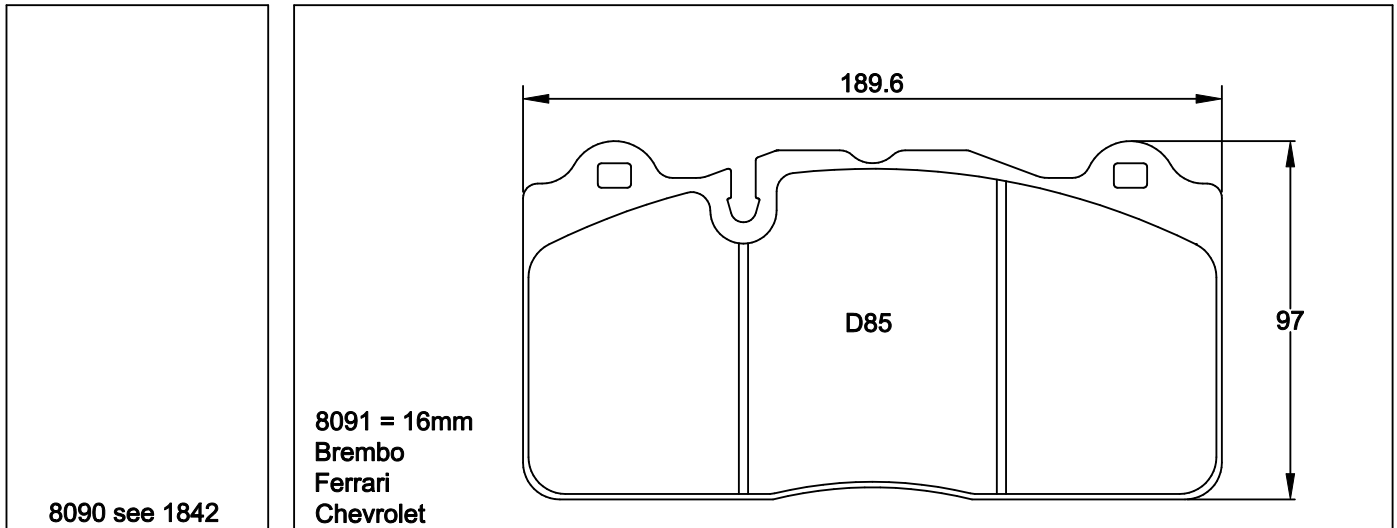

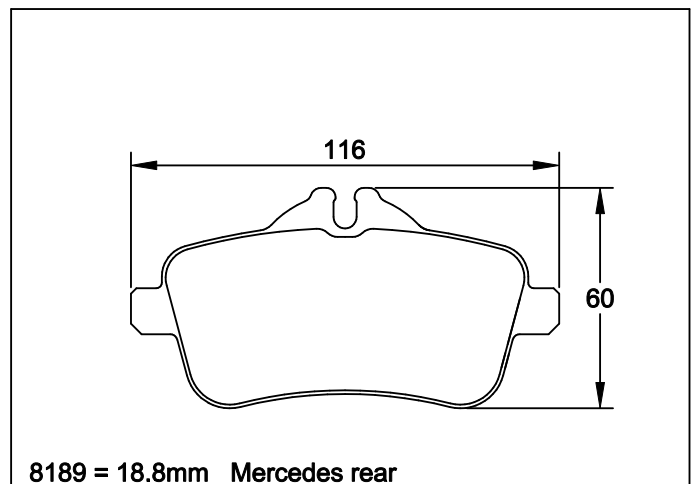
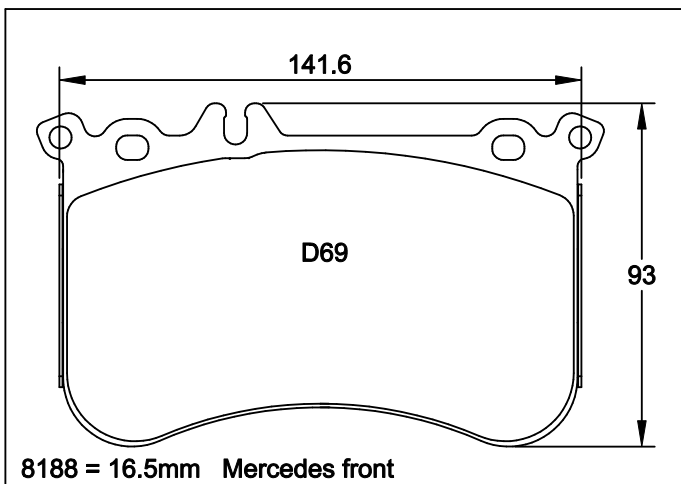
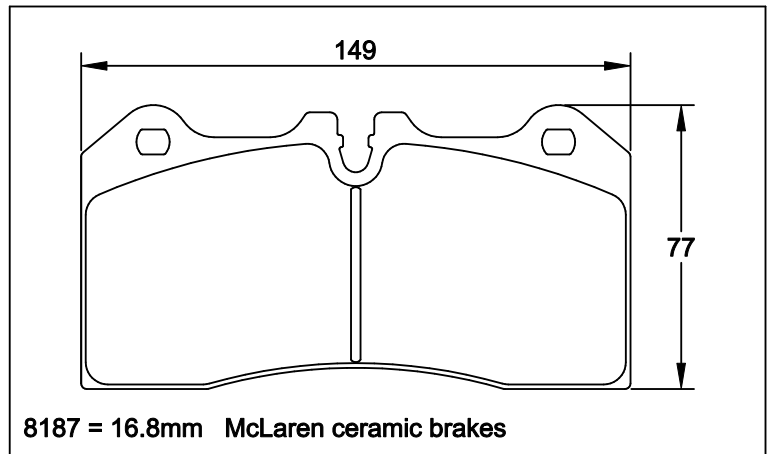
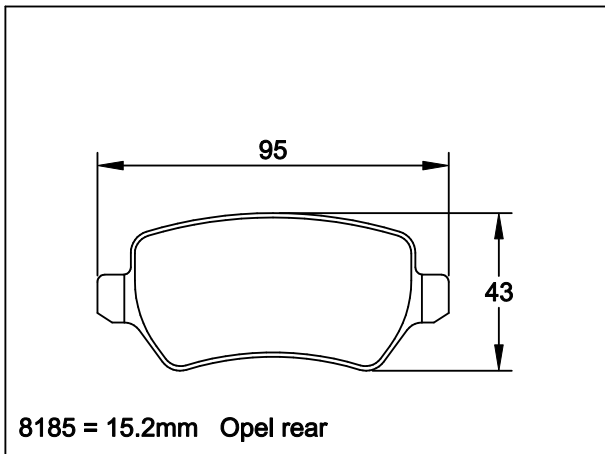
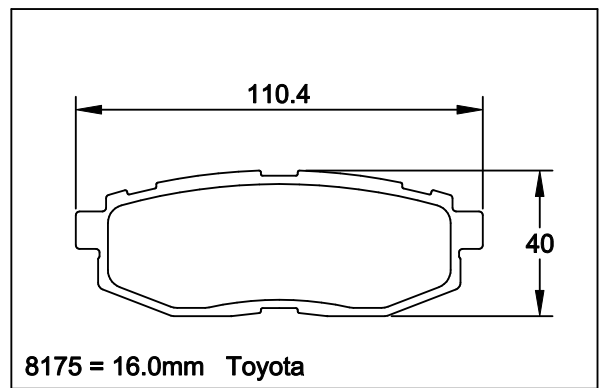
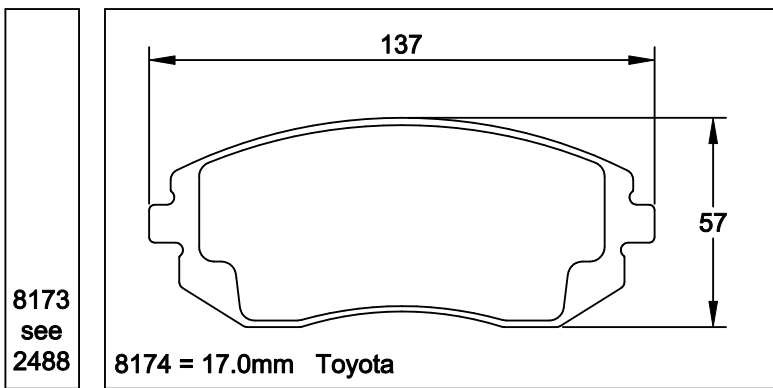
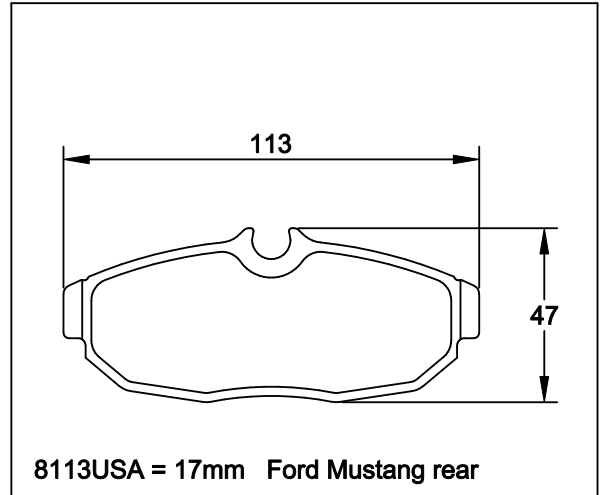
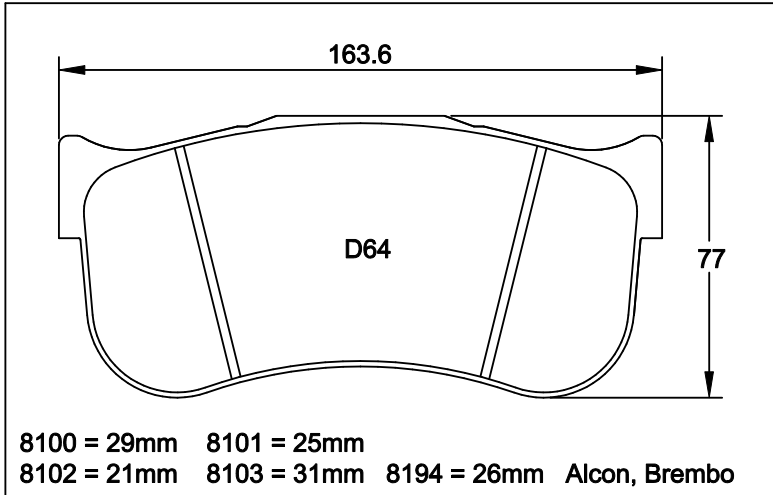

8191 see 1595

8192 see 1538

8193 see 1283

8194 see 8100

8195 see 2555

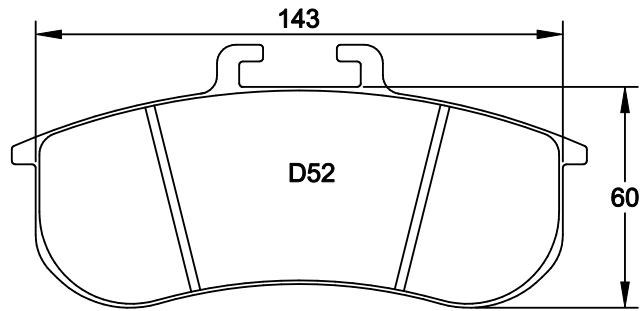

8197 = 27mm PFC, BMW

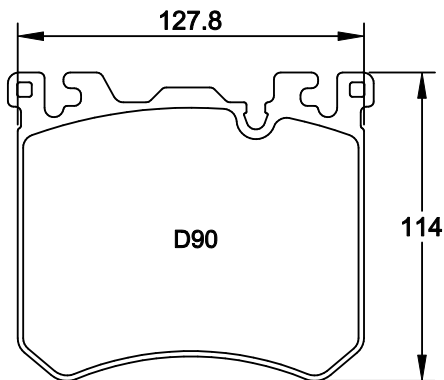

8200 = 18.2mm Alpina, BMW

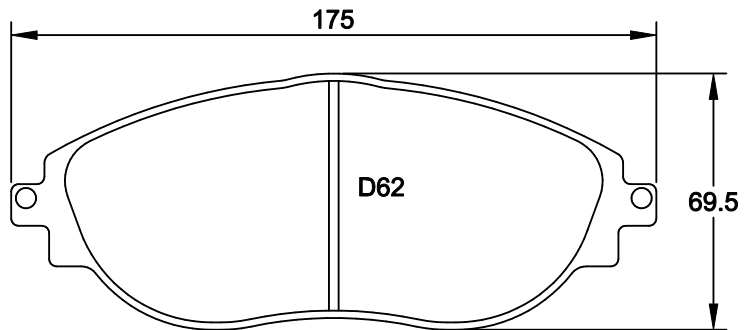

8201 = 19.5mm Audi, VW

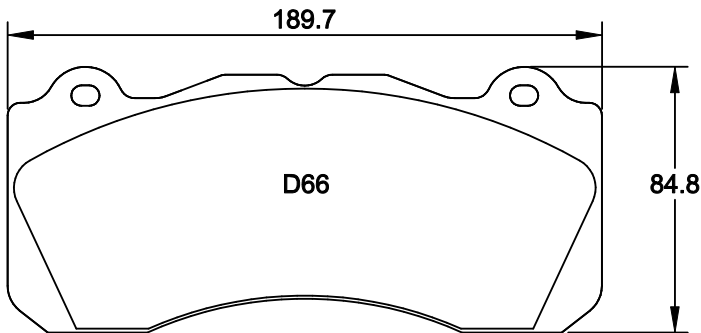

8203 = 15.5mm Ford front

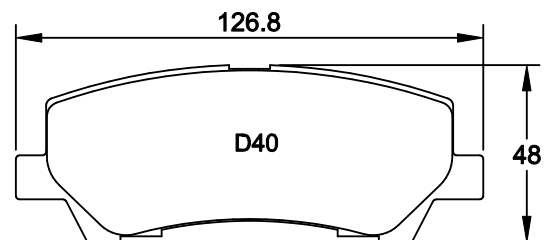

8204 = 17.5mm Ford rear

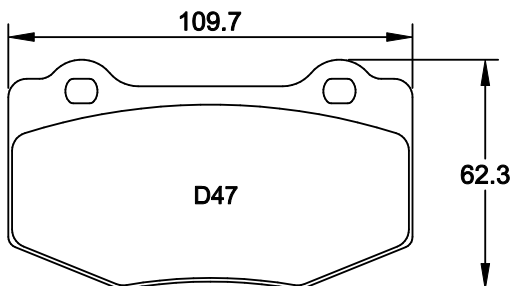

8208 = 16mm Brembo

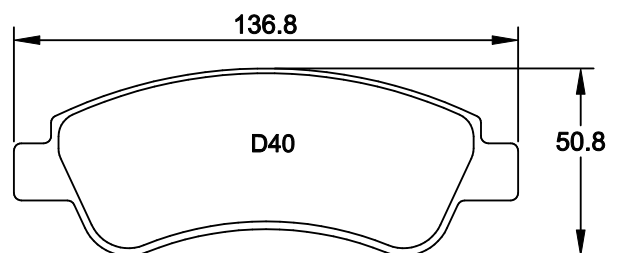

8212 = 19mm Citroen

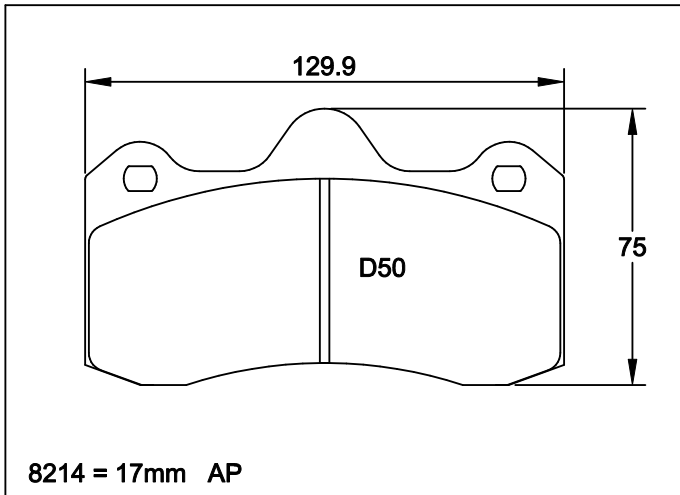

8216 = 18mm (See 2126 for shape)

8217 = 17mm (See 8049 for shape)

8222 = 25mm (See 2557 for shape)

8234 = 15mm (See 1538 for shape)

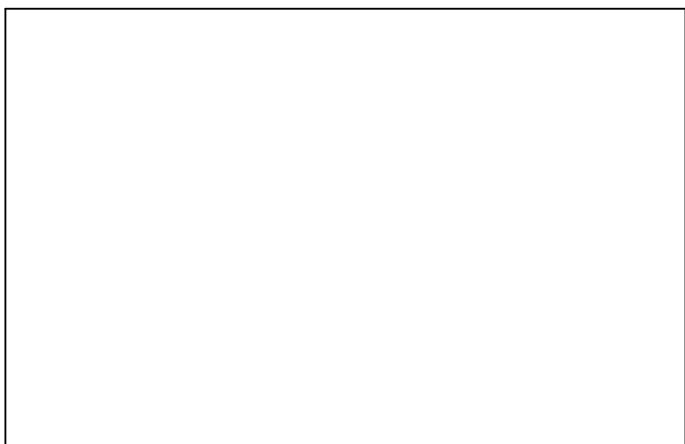
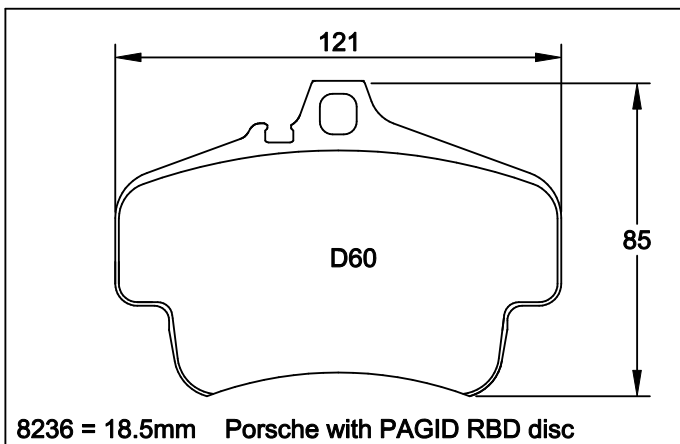
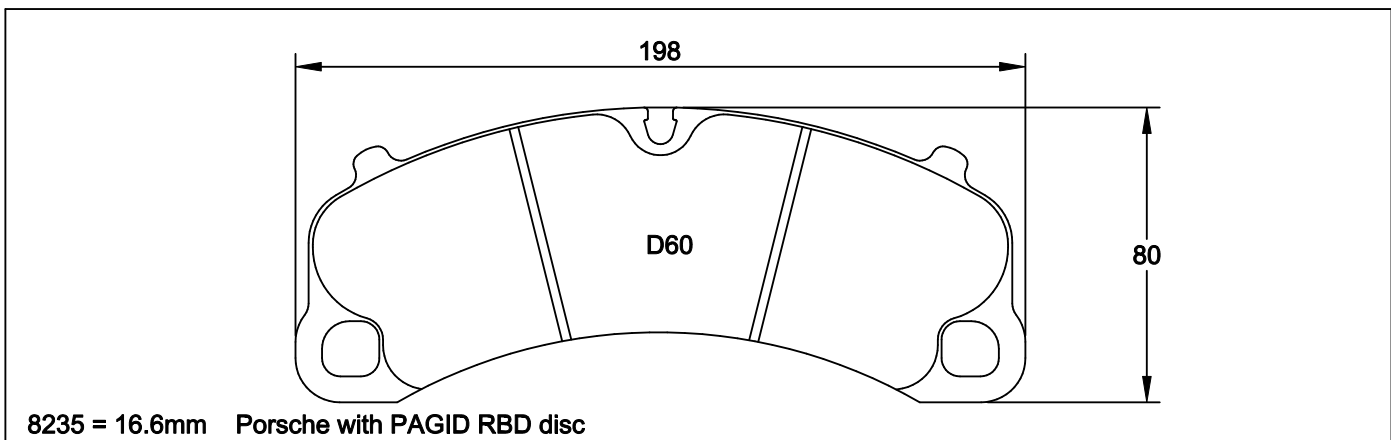



bt Bremsen Technik GmbH

Lüscherhofstraße 80

45356 Essen

Germany

Tel.: +49 201 36 09-0

info@bremsentechnik.de

www.pagidracing.com



bt Brake Technology of America

PO Box 152235

Cape Coral, FL 33915

Tel.: +1 239 540 1729

Fax.: +1 239 540 8539

pagid@braketechnology.com

www.pagidracing.com

Pagid is a registered trademark of

TMDFRICITION
A NISSHINBO GROUP COMPANY